

NOVEMBER 1973

BME

BROADCAST MANAGEMENT ENGINEERING

Indiana University

NOV 13 1973

IN 47401

UNIVERSITY LIBRARY
SERIALS DEPT
BLOOMINGTON



Insert exact amount
nickels, dimes & quarters
65¢
ALL BRANDS
FRANCIS & COMPANY DESIGN
USE
ANY COMBINATION OF
QUARTERS DIMES NICKEL

**To those who
want to know:
Ready access
to education.**

It's no big thing!



It's only a broadcast quality, portable **COLOR** camera that's priced under \$4000 and weighs less than 6 lbs.!

AKAI's new CCS-1505 Portable Color Camera weighs only 5.6 lbs. yet offers professional studio quality costing thousands more in any other camera.

The specifications tell the story:

- Completely compatible with any U.S. TV system
- Two vidicon system with separate Luminance and Chrominance channels
- S/N ratio: Luminance—Better than 40dB
Chrominance—Better than 30dB
- 525 line scanning, 2 to 1 interlaced, locked chroma
- Better than 300 line resolution
- Built-in 8 to 1 zoom lens
- Viewfinder—1.5" picture tube
- Built-in directional microphone
- Servo controlled iris
- Sensitivity control: 80 to 2,000 ft. candles (without filter)
- AC or battery operated
- Dimensions: 3 1/2" (W) x 10" (H) x 12" (D) including lens and grip

The performance of AKAI's new CCS-1505 color camera will amaze you! Whether you use it as the perfect tool for on location shooting or as an alternate studio camera...

But see for yourself! ...It's really no big thing!

From

AKAI™

The Innovators

AKAI America, Ltd / P.O. Box 55055,
Los Angeles, California 90055

↑
UP

NO USE
NO HOOKS
NEW
PRODUCTS

FROM:
DYNAIR
TO:
NAEB
New Orleans

CONTENTS

UNITS	ITEM
1	AUDIO SWITCHING ASSEMBLY
1	AUDIO-VIDEO EXCITER
3	PRODUCTION SWITCHERS
2	SPECIAL EFFECTS GENERATORS
1	SWITCHER AUDIO & VIDEO

See us at booths
56, 57 & 58

DYNAIR ELECTRONICS, INC.
6360 FEDERAL BOULEVARD
SAN DIEGO, CALIF 92114
TELEPHONE 714-582-9211



BM/E
CM/E



It's getting as easy to acquire education as it is a pack of smokes. Cassettes recorded on the spot (through pushbutton control) from information transmitted electronically from a central computer and dispensed by a vending machine is the concept of Robert Lightner, Cocoa Beach, Florida. Equipment courtesy Rowe Corp., New York City.

**BROADBAND
INFORMATION SERVICES, INC.**
274 Madison Ave.
New York, N.Y. 10016
212-685-5320

Editor
James A. Lippke
Associate Editor
Robin Lanier
Contributing Editor
M.L. Hollowell
Assistant Editor
A.E. Gehlhaar
Editorial Assistant
Alexandra N. Mills
Art Director
Gus Sauter
Production Manager
Arline G. Jacobs
FCC Counsel
**Pittman Lovett Ford
and Hennessey**
Publisher
Charles C. Lenz Jr.

- 6 Broadcast Industry News**
NAEB Convention Faces Era of Change
- 18 Need For Helical Standards is Acute, Engineers Panel Says**
- 22 FCC Rules & Regulations**
Fraudulent Billing Practices
- 34 Audio Processing for Diverse Programming**
How WGPR-FM handles a variety of music and talk shows.
- 40 The TV Mobile Truck in Education—"A Window on the Classroom"**
Practical installations devised by the University of Tennessee
- 47 High Schoolers Make "Laws" in Radio Assembly**
Commercial broadcaster WKRS finds way to help the education process—and boost audience.
- 48 Is Instructional Technology More Than a Promise in Higher Education?**
A recitation of stumbling blocks that will have to be removed.
- 50 Toward an Open Learning Society**
New technology and new attitudes make it possible to deliver what is known to those who want to know it . . . outside of the traditional classroom.
- 61 Focus on Tamaqua**
How one high school got immersed in instructional TV.
- 69 Broadcast Equipment**
New and significant products for broadcasters.
- 74 New Literature**
Useful reading materials.

CM/E Magazine: For those with cable interests/following page 68.



BM/E, BROADCAST MANAGEMENT/ENGINEERING, is published monthly by Broadband Information Services, Inc. All notices pertaining to undeliverable mail or subscriptions should be addressed to 274 Madison Ave., New York, N.Y. 10016. BM/E is circulated without charge to those responsible for station operation and for specifying and authorizing the purchase of equipment used in broadcast facilities. These facilities include AM, FM, and TV broadcast stations; CATV systems; ETV stations; networks and studios audio and video recording studios; consultants, etc. Subscription prices to others: \$15.00 one year, \$25.00 two. Copyright © 1973 by Broadband Information Services, Inc., New York City. Application to mail at Controlled Circulation postage rates pending at Easton, Penna.



SYSTEMS

GVG's product and engineering capability extends from basic terminal components through complete integrated systems delivered on a turnkey basis.

Such systems involve switching matrices for program production and special effects, routing or distribution of video and audio signals, and timing pulse delegation and distribution. An additional system consideration is the assign-

ment of remote control of telecine and videotape equipment from one studio to another.

Custom engineering can be provided for control systems, which are frequently complex and may utilize programmable sources of automation.

Large system or small, we welcome the opportunity to respond to any technical inquiry.

THE GRASS VALLEY GROUP, INC. 

SOLD EXCLUSIVELY BY GRAVCO SALES, INC.

6515 Sunset Blvd.
LOS ANGELES, CALIF.
(213) 462-6618

Station Plaza East
GREAT NECK, N.Y.
(516) 487-1311

125 South Wilke Road
ARLINGTON HEIGHTS, ILL.
(312) 394-1344

Redbird Airport
DALLAS, TEXAS
(214) 330-1245

1644 Tullie Circle, N.E.
ATLANTA, GEORGIA
(404) 634-0521

OVERSEAS - GRASS VALLEY INTERNATIONAL - BOX 1114, GRASS VALLEY, CA 95945 - USA

Circle 102 on Reader Service Card

BROADCAST INDUSTRY NEWS

NAEB Meets in Era of Change

Major change, both in its own organization and in the field with which it is concerned, will dominate the annual meeting of the National Association of Educational Broadcasters, running November 11 to 14 at the Marriott Hotel in New Orleans.

It is being called an "umbrella convention" because all important groups and organizations dealing with public broadcasting will have joint or separate programs at the same time and place, including the Public Broadcasting Service, the Corporation for Public Broadcasting, and National Public Radio. About 5000 registrants are expected.

NAEB itself, as previously widely reported, is changing its character from that of a trade association of public broadcast stations to a professional society serving individual mem-

Ampex Debuts Miniature VTR



A miniature video recording machine, easily hand-held, weighing only eight pounds with a battery pack, and using one-inch tape in a helical scan wrap, was announced by Ampex Corporation. Called the MS-1, the unit has a 20-minute recording time, a bandwidth of 3.5 MHz, dynamic range of 35 dB, and takes only 40 watts of power, supplied by the matching nicad battery pack. It is intended for instrumentation recording in analog or digital form, as well as television.

bers. The membership will be asked during the convention to vote on final ratification of the plan.

Changes in the field of concern are recognized by one of the main topics of the discussions: the use of telecommunications other than broadcasting for education. Some of the other major emphases of convention sessions will be maintaining freedom of the media, and long-range financing for public broadcasting.

Among the guest speakers will be Amos Hostetter, chairman of NCTA; Carl Rowan, newspaper columnist; Roger Heynes, president of the American Council on Education; and Federal Communications Commissioner Rex Lee.

Kodak Will Sponsor Royal Wedding Telecast

The Eastman Kodak Company will be the sole sponsor of a live telecast on CBS of the wedding of Princess Anne of Great Britain to Captain Mark Phillips, from 5 to 9 a.m. (EST) on November 14. Coverage, with Sally Quinn and Charles Collingwood as anchorpersons, will include a first look at Princess Anne's wedding gown, interviews at the departure from Buckingham Palace, and the ceremony in Westminster Abbey, which starts at 6:30 a.m. EST.

NAB For FCC Only Debate on Pay TV

Willard E. Walbridge, chairman of the NAB's Special Committee on Pay TV, has written to David Foster, president of the National Cable Television Association, proposing oral argument before the FCC on the whole question of pay TV and cable. Mr. Foster had earlier written the NAB asking for a serious debate on the issues; Mr. Walbridge has now put the NAB on record as wanting the debate to be before "all the Commissioners and appropriate staff" of the FCC, adding that the debate is "long overdue."

FCC Denies Plea For Fewer TV Channels

The FCC has turned down a request from the Consumer Electronics Group of the Electronic Industries Association that capability for tuning chan-

nels 70 through 83 be no longer required on standard TV tuners. In refusing the request, the FCC said that the benefits to the industry would amount to a few cents on each receiver, whereas the cost of moving the many translators now assigned channels between 70 and 83 would be very substantial for the operators, many of whom are non-profit organizations. Assignment of UHF channels to land mobile use, now underway, will not conflict with most TV translator use for many years, if ever, the FCC maintained.

NAEB Gets \$150M From Ford

The National Association of Educational Broadcasters has received a one-year \$150,000 grant from the Ford Foundation for general support of the change-over to a professional society of individual members. The grant, according to the announcement, is not restricted to any particular program, but will aid the full range of programs, covering professional development, information and publications, and research and planning.

FCC Delays 25-Mile Rule

The FCC delayed from September 7 to November 12 the effective date of a new rule (Docket 18179) giving television stations exclusive rights to non-network and syndicated programs not only in their own communities, but in others less than 25 miles away. A delay had been asked by the Association of Maximum Service Telecasters, the National Association of Broadcasters, and a number of individual station managements, to give them time to prepare arguments opposing the rule. AMST has already said that the rule would prevent television stations in at least 35 of the 100 top markets from getting exclusive rights against direct competitors in their own multi-city markets.

NASA Orders Scientific-Atlanta Ground Station

Scientific-Atlanta has signed a contract with the National Aeronautics and Space Administration to supply a ground station for the Communica-

continued on page 8

WHAT'S
THIS?
A QUAD HEAD
WITH A
500-HOUR
WARRANTY?"

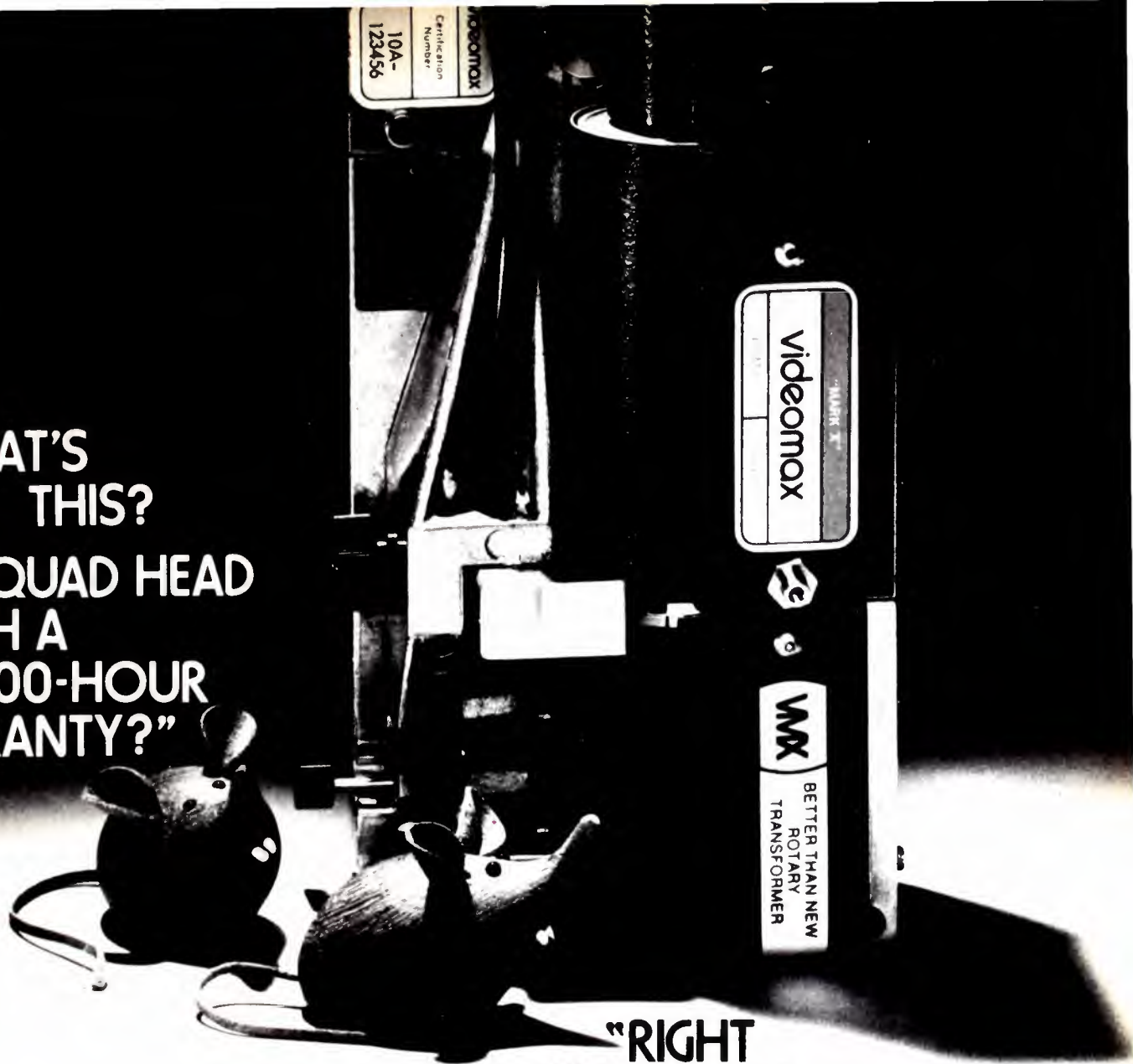

"RIGHT
AND BETTER
THAN
NEW!"

Welcome Max and Maxine. They've got a lot of good things to tell you about VIDEOMAX, the innovators.

Broadcasters have asked for it. Now VIDEOMAX, the VTR quad head specialists, offers the "L" series refurbished head assembly, **better than new**, with a **500-hour warranty** at a price of only \$950. How do we do it? Engineering innovation from the company whose only business is providing you with the finest quad heads available.

More good news. VIDEOMAX has also extended warranty on its current product now known as the "M" series from 150 to 200 hours at \$800. This series is engineered for the most demanding, highly critical applications.

The choice is yours. Both the "L" and "M" series carry the same "no risk" trial offer. Both series are available in all Mark III and Mark X configurations. We'll continue the same fast service—ten working days or less—and we have the only field force dedicated to this business.

When you return a video head to us, it is completely refurbished from stem to stern. Every unit is then certified to meet or exceed the industry's highest standards, insuring total compatibility. It's only because we're the innovators that we can offer you these fantastic new warranties.

Careful Max and Maxine. We've built the better mousetrap.

For more information, write or call collect.

 **videomax**

Videomax Corporation
Subsidiary of Orrox Corporation,
154 San Lazaro Avenue, Sunnyvale, California 94086.
Phone: (408) 739-5391

www.americanradiohistory.com

Prodelin[®]

gets it all together

Like all Prodelin transmission line components, our rigid coaxial cable is the finest. But that's not enough.

In the fast-moving broadcast field you need more; you need action! Speedy delivery, precision-engineered components, simplified installation, and high performance. You get them from Prodelin.

We have the industry's largest inventory of transmission system components. Your custom system is in stock now, with quick shipment from New Jersey or from California. In an emergency, 8 to 48 hour shipping service is free on most standard items. And when you get it, it arrives on site safely; it goes up quickly and correctly. Our advanced technology enables us to provide components optimized to your exact operating frequency at no extra charge.

We also offer your complete transmission system fully tuned to 1.05:1 VSWR or less, all completely match-marked as it was assembled here at the factory. This is available at a slight additional charge.

For any transmission line need, whether commercial or military, ask Prodelin. Just call or write, with frequency and system details.

Prodelin[®] Inc.

Hightstown, New Jersey 08520
Phone (609) 448-2800
Santa Clara, California 95050
Phone (408) 244-4720

Circle 104 on Reader Service Card

NEWS

tions Technology Satellite program, which will assess the use of satellites in reaching remote and sparsely populated areas. The joint U.S.-Canadian project is scheduled to get underway with launch of a satellite in early 1975, and will include telephone, two-way educational TV, data, and newspaper transmission, as well as TV programming. Scientific-Atlanta has already delivered and installed in Ottawa equipment for tracking, telemetry and command for the orbiting satellite.

Zenith Reports Fire Hazard in TV Sets

Zenith Radio Corporation identified certain of their 19-inch color TV sets that presented a possible fire hazard from an improper location of a high-voltage capacitor. Zenith said they had taken immediate steps to notify all purchasers of the sets to unplug them and contact dealers for a free modification that would remove the hazard. The sets, sold mostly during summer and fall of 1972, carry model numbers D4030W5, D4030W6, D4032W5, D4034P6, and T2838W6; but only those with the following serial numbers are affected: 6505665-6508999; 6513900-6514999; 6525385-6526999; 6527000-6529999; 6536000-6539427; 6550000-6550669; and 6553000-6553720.

Ascertainment for Public TV Proposed

The responsibility for ascertaining community program needs, now imposed on commercial broadcast stations, should be imposed on public broadcasters as well, according to a petition to the FCC from Black Associations, a public-interest group. The rationale is that many public TV stations now air general news, public affairs and cultural programs, going far beyond education as such. The National Association of Educational Broadcasters has supported the petition, and the FCC has invited comments under Docket 19715, which concerns ascertainment requirements in general.

NSF Offers Graduate Fellowships

The National Science Foundation will award early in 1974 up to 500 fellowships for full-time study leading to a master's or doctor's degree in the social sciences, mathematics, or engineering. Those chosen will get \$3600 for each 12 months of the three-year program, but with no dependency allowances. For application forms, write or

continued on page 10

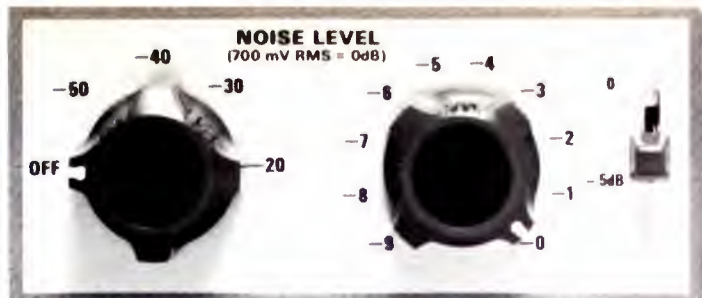

easy

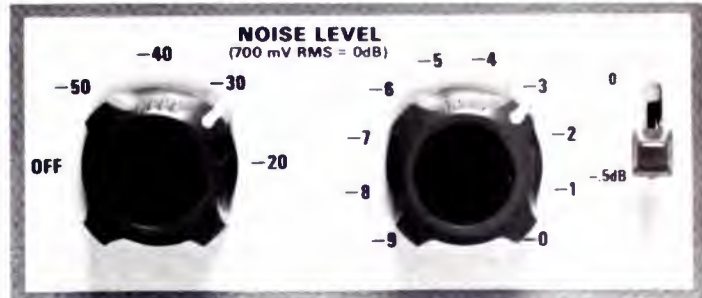
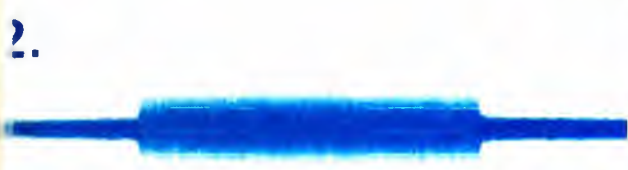

in-service

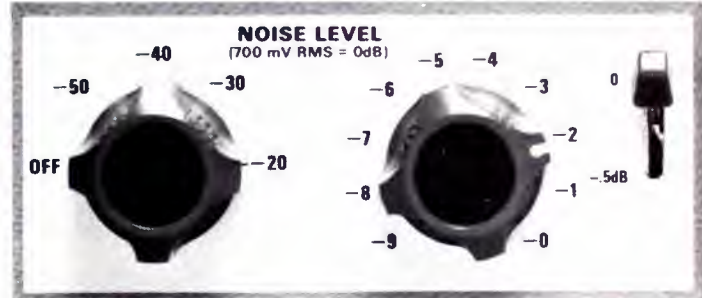

noise measurement



the TEKTRONIX 1430

is easy to make in-service or out-of-service noise measurements with the TEKTRONIX 1430 Random Noise Measuring Set. An error-free, side-by-side comparison technique is used. **1.** A portion of the line is deleted. **2.** A calibrated noise level is then inserted into the TEKTRONIX 1430. **3.** The noise level to be measured and the 1430's calibrated noise output are then matched side-by-side on a waveform monitor or scope. This method is highly accurate. In-service noise measurements, using a

selected line in the vertical interval, are made with better than 2-dB accuracy. And the measurements are meaningful in terms of what you see on a picture tube because CCIR weighting and low-pass filters are built in. Accurate, repeatable measurements are convenient to make in cameras, VTR's, STL's transmission systems or wherever video-frequency random-noise is a problem. Of course program material is protected with copper-to-copper safety. Tests

can even be performed in the absence of composite sync using the 1430 generated horizontal sync. Full-field measurements can be made with resolution approaching 0.5 dB. For more information about the Tektronix noise measurement technique, contact us at P.O. Box 500-A, Beaverton, Oregon 97005.

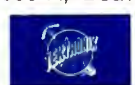

in Europe —
TEKTRONIX LTD.
Guernsey, C.I., U.K.

TEKTRONIX®

committed to technical excellence

Circle 105 on Reader Service Card
For demonstration:
Circle 106 on Reader Service Card

The Best Choice For AM Monitoring

NEW modulation only or



frequency and modulation



...both meet new FCC rules

New will comply with the new FCC stationing requirements and meet budget goals. They get the accuracy and speed you'll expect from the world's most advanced monitor.

For modulation only, choose the Model 734. For frequency and modulation, choose the Model 735.

Both have a built-in frequency PLL feature. They have a built-in auto-tune feature with a built-in auto-tune.

Both have a built-in auto-tune feature with a built-in auto-tune. They have a built-in auto-tune feature with a built-in auto-tune.

Both have a built-in auto-tune feature with a built-in auto-tune. They have a built-in auto-tune feature with a built-in auto-tune.

Both have a built-in auto-tune feature with a built-in auto-tune. They have a built-in auto-tune feature with a built-in auto-tune.

Both have a built-in auto-tune feature with a built-in auto-tune. They have a built-in auto-tune feature with a built-in auto-tune.

Both have a built-in auto-tune feature with a built-in auto-tune. They have a built-in auto-tune feature with a built-in auto-tune.

TFT TIME AND FREQUENCY TECHNOLOGY, INC.
1000 DELCOTT STREET, SANTA CLARA, CA 95050 (408) 246-6000

Circle 10 on Reader Service Card

NEWS

call Fellowship Office, National Research Council, 2101 Constitution Avenue N.W., Washington, D.C. 20418. Deadline for applications is November 26, 1973.

Nashville Will Get First Black-Owned TV

Slated to be the first black-owned television station to go on the air in the country, WMCV-TV Channel 17, in Nashville, Tenn., is being groomed for opening late in 1974, according to an announcement from Hudson Broadcasting Company, which acquired the station assets in August. Robert D. Hudson, Jr., president, and a 17-year veteran of broadcasting management said, "We are deciding on our equipment package and doing the necessary staffing for the earliest possible operational date." The station has been off the air for several years.

Study Seeks Children's Attitudes to TV

Called a "pilot study" to provide insights into what children learn and what values and attitudes they get from radio and television, a series of extensive interviews with Milwaukee public school children is underway under joint sponsorship of the schools and the National Association of Broadcasters. The tape-recorded interviews, according to James H. Hulbert, NAB public relations vice president, should "yield information of interest to broadcasters (and others) about the effects of radio listening and TV viewing as perceived by youngsters themselves."

Network TV Ads Up 6% in August

Advertisers spent \$124 million in network TV in August 1973, against \$116 million in August, an increase of 6.3%, the Television Bureau of Advertising reported. For the eight months ended August 31, said TVB, the total was \$1.2 billion, against \$1.1 billion in the first eight months of 1972.

Signetics Opens FET Design Contest

With a 1974 Vega car as a first prize, Signetics has opened a contest for best designs using any of its new DMOS FETs. Each contestant gets a free design kit with the FET he intends to use. Second prizes are two HP-45 calculators; third are 25 hand-held calculators. Contest closes January 15,

continued on page 12

Ready to Solo?



Lately, more and more TV-newsfilm cameramen have been called upon to go it alone—responsible for both picture and sound. With our CP-16/A news / documentary camera you are ready to "take off" in no time. Ready to go any place. Cover any assignment. Solo or not.

The CP-16/A is the ideal camera to solo with. Grab the handle of a CP-16/A, and you pick up a complete camera and sound system. Lightweight, rugged, dependable. And extremely silent in operation.

The compact CP-16/A rests easily on your shoulder, its silhouette low and unobtrusive. Its balance makes the CP-16/A feel as comfortable and natural as an extension of your own body. Its total systems design gives you complete freedom to "do your thing" as it was meant to be done.

Freedom to move in and out of tight shooting situations. Freedom to mingle in a crowd without distracting it. To merge with the action without intruding on it.

The CP-16/A Crystasound amplifier is built-in—designed from its very inception to be an integral part of a total modular camera and sound system. An amplifier system not tacked on. Not an afterthought. The Crystasound 3XL magnetic record/playback head provides extra long life, and never requires adjustment.

The CP-16/A also features a snap-in nicad battery which will drive some 4000 feet of film on a single charge; Mitchell-type 400 ft. or 1200 ft. magazines which can be instantly attached to the camera due to a unique spring-loaded sliding latch; and a super accurate crystal controlled motor, making the CP-16/A an outstanding sound camera—both single *and* double system sound.

The CP-16/A is a no fuss, no hassle camera. No fidgety frills. No headaches. No backaches.

So you can concentrate on the action. And capture it on film. Picture *and* sound. Solo or not.

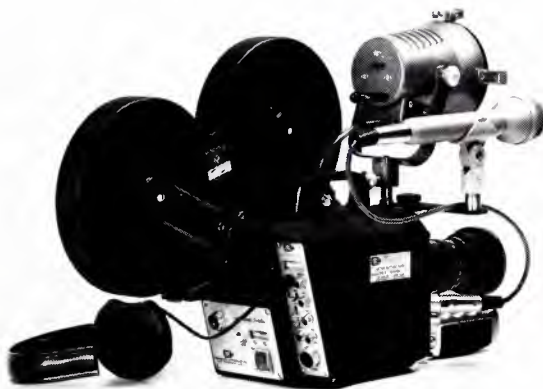

**The CP-16/A
... a cameraman's
kind of camera.**



For further information, please write to:

cinema E products
CORPORATION

Technology In The Service Of Creativity

2044 Cotner Avenue, Los Angeles, California 90025
Telephone: (213) 478-0711 ■ Telex: 69-1339 ■ Cable: Cinedevco

Circle 108 on Reader Service Card



CP-16/A camera shown with Mike/Lite bracket, RE50 microphone, and Cinema Products' new *Sturdy-Lite* quartz 250-watt/30V battery-operated focusing spot light. The *Sturdy-Lite* focusing spot weighs only 12 ounces!

1974. Info: Signetics, 811 East Argues Avenue, Sunnyvale, Calif. 94086.

FCC Gives Go-Ahead to Five Domsats

Wide use of satellites for domestic telecommunications moved noticeably nearer with FCC granting of authorizations for five additional systems, proposed by American Satellite Corporation, (jointly owned by Fairchild Industries Inc. and Western Union International); RCA Global Communica-

tions; GTE Satellite Corp. (GTE), and National Satellite Service, Inc., (subsidiary of Hughes Aircraft); AT&T Co.; and Communications Satellite Corporation. An earlier authorization went to Western Union Telegraph Co. Two of the authorizations, those to ASC and RCA, covered initial use of the Canadian ANIK satellite. Other authorizations covered various combinations of satellite launchings, earth stations, and interconnection facilities.

Kodak Funds Movie Director Series on PBS

Public service station WNET-TV, New York, will produce a series, "The Men

Who Made the Movies," a study of eight leading movie directors, with a grant from the Eastman Kodak Company. The first program will be aired November 4, and all will be carried by the 237 affiliates of the Public Broadcast Service Network. Directors whose work will be sampled and discussed are Frank Capra, George Cukor, Alfred Hitchcock, Howard Hawks, Vincent Minnelli, Raul Walsh, William Wellman, and King Vidor, with Richard Schickel, film critic, as producer and narrator.

Briefs

GTE Sylvania will acquire Union Insulating Co. of Parkersburg, W. Va., by merger if stockholders approve ... JVC America Inc. said they expected a U.S. patent for the Shibata stylus, and would immediately license U.S. makers ... General Cable Corp. has moved their executive office, in New York City since the late 1920s, to Greenwich, Conn.

Cramer Video, pro electronics supplier of Needham Heights, Mass., announced franchises to distribute JVC and Conrac products in New England, Maryland, Washington, and Virginia ... Oak Industries said it was selling all non-equipment activity in the security and protection fields ... Raytheon will supply display terminals and associated equipment to Eastern Air Lines for automated ticket service in 14 cities.

RCA announced plans for an \$8 million plant to manufacture semiconductor in Kuala Lumpur, Malaysia ... Magnavox has contracts with Warner Cable Corp. to supply \$3 million of distribution equipment for cable systems in Wisconsin and South Carolina ... Memorex Corp. claimed lead over all other makers in sales of premium cassettes in June 1973, with a 22% advantage over Scotch, the number two firm.

Great Plains National is offering a 30 part college-level color series, on two-inch tape or U-matic cassettes, covering human growth and development; data, Box 80669, Lincoln, Neb.

Korn/Ferry International, U.S. executive search firm with offices in ten cities, will merge with G.K. Dickinson Ltd., British firm in the same field, and expand into European markets.

Marconi has orders for over \$4 million of color TV equipment for Australia's color service, scheduled to begin April 1975; sales were through Amalgamated Wireless of Australia ... Practising Law Institute will hold a two-day seminar (November 29 and 30 at the St. Regis in New York; December 6 and 7 at Sir Francis Drake in San Francisco) on the legal and business

continued on page 16



Spotmaster®

Space
Setter



5 3/8" height
5 5/8" width

\$469

Three/70™ Cartridge Playback Deck

Meet our midget. And don't be fooled by its modest exterior. The new Spotmaster® Three/70 packs the performance of its big brother—the incomparable Ten/70—into a pint-sized package at a pint-sized price.

Standard features include the Ten/70's direct drive synchronous motor, all silicon solid state circuitry, high output (+8 dbm) and plug-in modular construction. Deck operation is pushbutton-quick, with instantaneous response.

Now look what happens when you put a trio of Three/70s together. They fit side by side in a single rack mount. The whole thing takes up just 7" of rack space.



Three/70s accept all Type A cartridges, playing up to 10½ minutes at 7½ ips. Options include 3¾ ips operation, as well as 150 Hz and 8 kHz secondary and tertiary cue tones (to augment the 1,000 Hz primary stop/re-cue tone).

Good things do come in small packages. Learn more about the Three/70—contact us today.

BROADCAST ELECTRONICS, INC.

— A Filmways Company —

8810 Brookville Road, Silver Spring, Maryland 20910 • (301) 588-4983
TWX 710-825-0432

Why our time base correctors should be the apple of your eye

Proven Flexibility in Standalone Time Base Correctors

Regardless of your VTR—power line-locked, capstan servo'd/V-locked, or H-locked—our Delta Series Time Base Correctors and Hue Shift Correctors offer standalone processing of all color signals—either NTSC direct, "NTSC-type" or heterodyne "color under." And in monochrome—either RS-170 or RS-330 industrial sync.

Offering the best economy and flexibility, the Delta 44-328 HETROCOLOR™ TBC works with all types of monochrome and color VTRs. Particularly in cassette VTRs without our TBC, the color tape will be a long way from FCC acceptance. Aside from independently varying sync and sub-carrier frequencies, editing capabilities are marginal. The HETROCOLOR TBC is the only unit on the market that allows transfer of heterodyne record VTR signals to a broadcast VTR. Second generation playback of this tape through the TBC corrects the color signal for broadcast with clean electronic splices.

For the best cost/performance package in the business, select the standalone Delta 44-200 NTSC Direct Color TBC coupled with the Delta 7 VELCOR Hue Shift Corrector for the finest in broadcast color processing.

And if you're staying with monochrome somewhere in your system, our Delta 44-028 TBC combines broadcast specs with our lowest price.

For more flexibility, we've added the Delta 23/3.58MHz subcarrier generator as an accessory to the Delta 44-328 TBC for combined outputs that are the equivalent of a broadcast stable NTSC color sync generator.

Exclusive Features of Our Growing TBC Family

Optimized Design. Of the several ways to eliminate time base error generated by all VTRs, we primarily use binary related delay lines which are switched in or out of the signal path at line rate. This technique offers the highest output performance looking at all the critical specifications of signal to noise ratio, bandwidth, differential phase and differential gain. There is no tampering with the visual portion of the picture. There is no contouring and quantizing noise as in digital techniques, or differential phase/gain variation as in EVDL techniques.

Velocity Error Corrector. In NTSC direct playbacks from 1" helical and all quad VTRs, color streaking (velocity error) is another problem that must be solved when either interchanging tapes or dubbing through several generations. Adding our Delta 7 VELCOR™ Hue Shift Corrector in front of any broadcast quality TBC, you get faithful color reproduction as well as imperceptible time base jitter throughout the entire picture.

Universal Color Corrector. In "NTSC-type" and "color under" playbacks from 1/2", 3/4" and 1" VTRs, all you need is our exclusive HETROCOLOR TBC, despite the wide variety of color recording and recovery techniques.

Full Proc Amp. All Delta Series TBCs have a built-in Delta 21 proc amp with front panel controls for video gain, setup, chroma gain, and chroma phase. The plug-in Delta 28 with front panel controls for gen-lock tracking rate and H-phase timing is included in all Television Microtime models working with less sophisticated VTRs.

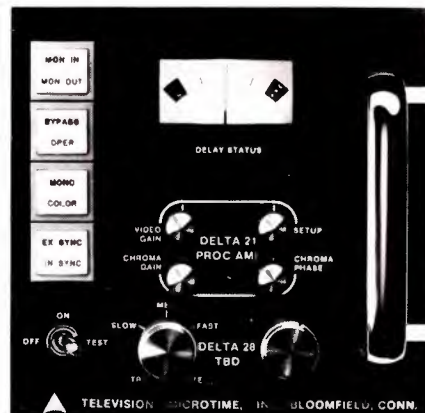

TMI's exclusive built-in Delta 21 proc amp and Delta 28 TBC.

Front Panel Switches. All our TBCs have illuminated front panel switches to provide easy selection of operating modes. These include separate monitor and program video outputs on separate in/out and operate/bypass switches. A failsafe program bypass exists to handle power loss.

Experience is Our Guide

We introduced the first of our Delta family at the Chicago NAB Show in April 1972 and delivered our first production unit to the University of North Carolina two months later. In March 1973 at the Washington NAB Show we introduced two additional TBC models, the Delta 7 Hue Shift Corrector and several accessories. We are now delivering this family of products that work with the whole spectrum of VTRs from 1/2" helical to 2" quad.

But our experience goes back even further. In addition to developing custom TBC products for the networks, we've been supplying delay lines to Ampex Corporation who builds them into the full line corrector in their AVR-1 Teleproduction Recorder.

Look at Who Has What in Time Base Correctors

Review the chart then call us for a demonstration. We're sure you'll be as pleased as our many customers are—in every segment of the television industry—broadcast, CATV, education, medicine, industry, research, government, and OEM. Contact us. Television Microtime.

AVAILABLE FROM LEADING TELEVISION DISTRIBUTORS THROUGHOUT THE UNITED STATES AND CANADA.



	Ampex	RCA	IVC	TMI	CVS
MONO					
All Mono VTRs				44-028	
COLOR					
1/2" line/V-lock				44-328	*502
3/4" line lock				44-328	*502
1" line lock				44-328 7-001	*502
1" V-lock				44-328 or 44-200 (with 14)	500
				7-001	
1" H-lock				44-328 or 44-200	500
			4102	7-001	
2" Quad				44-200 or 44-328	500, if VTR has AMTEC or ATC
				7-001	

* Announced last June (ask CVS about availability — and specs)

How do you like them apples?



TELEVISION MICROTIME, INC.

1280 Blue Hills Ave., Bloomfield, Conn. 06022

(203) 242-0761

The automated VHF transmitter

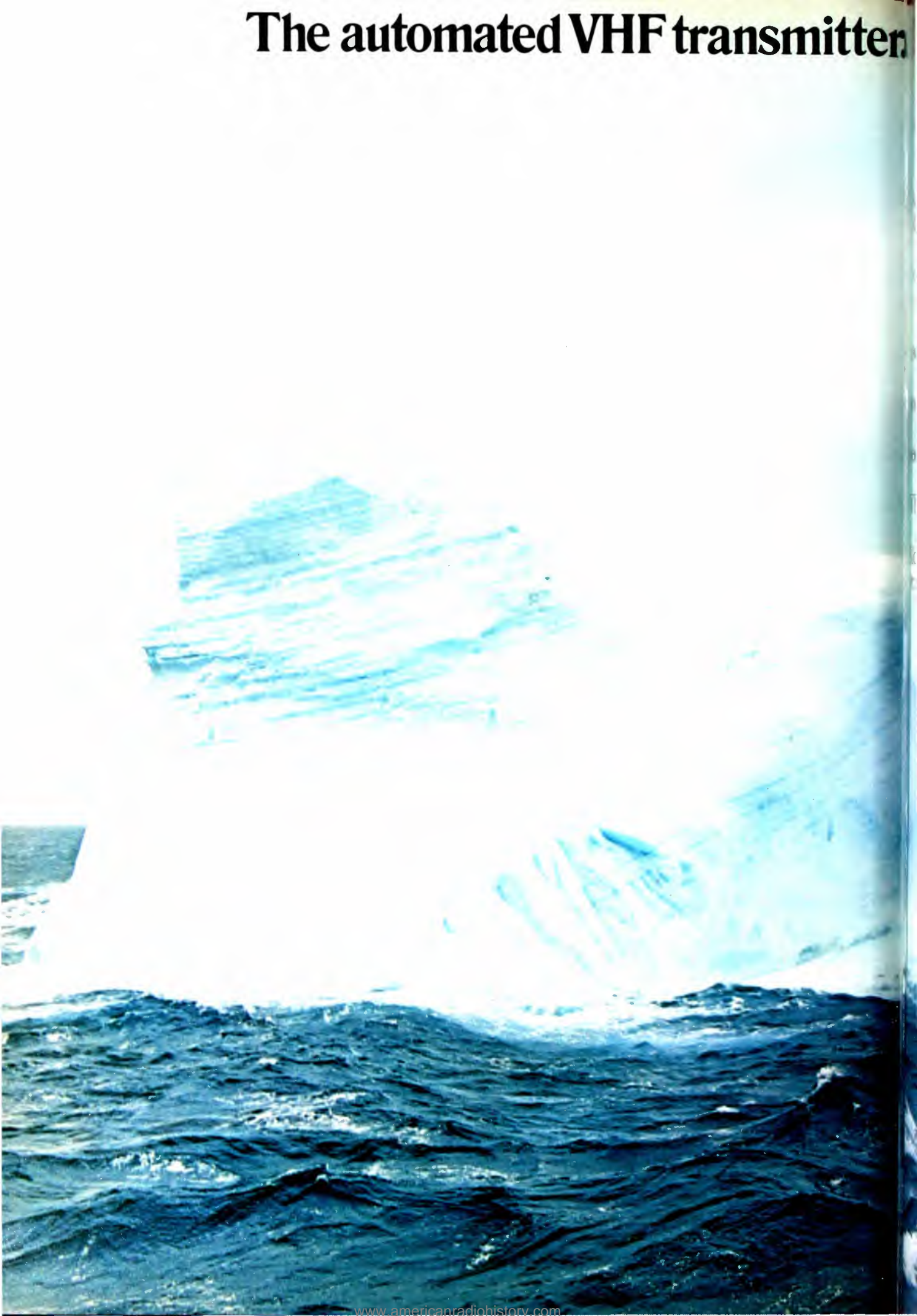

The real thing...not just a remote possibility.

The entire "F" line of RCA transmitters is now automated.

So they need far less operator attention.

Every tube not absolutely essential was designed out. That means fewer tubes model-for-model than any other VHF transmitter.

We took out as many tuned circuits as possible. For instance, our totally solid-state IPA has no controls to drift or adjust.

We deleted all the blowers except one. And that controls the whole transmitter.

Then we added automatic control of output power and sync level so you don't have to readjust power.

We topped it off by building in the functions you need for complete remote control.

Result: transmitters that require less attention. Wherever they're stationed.

For further details, write RCA Broadcast Systems, Bldg. 2-5, Camden, N.J. 08102. See your RCA representative.

RCA

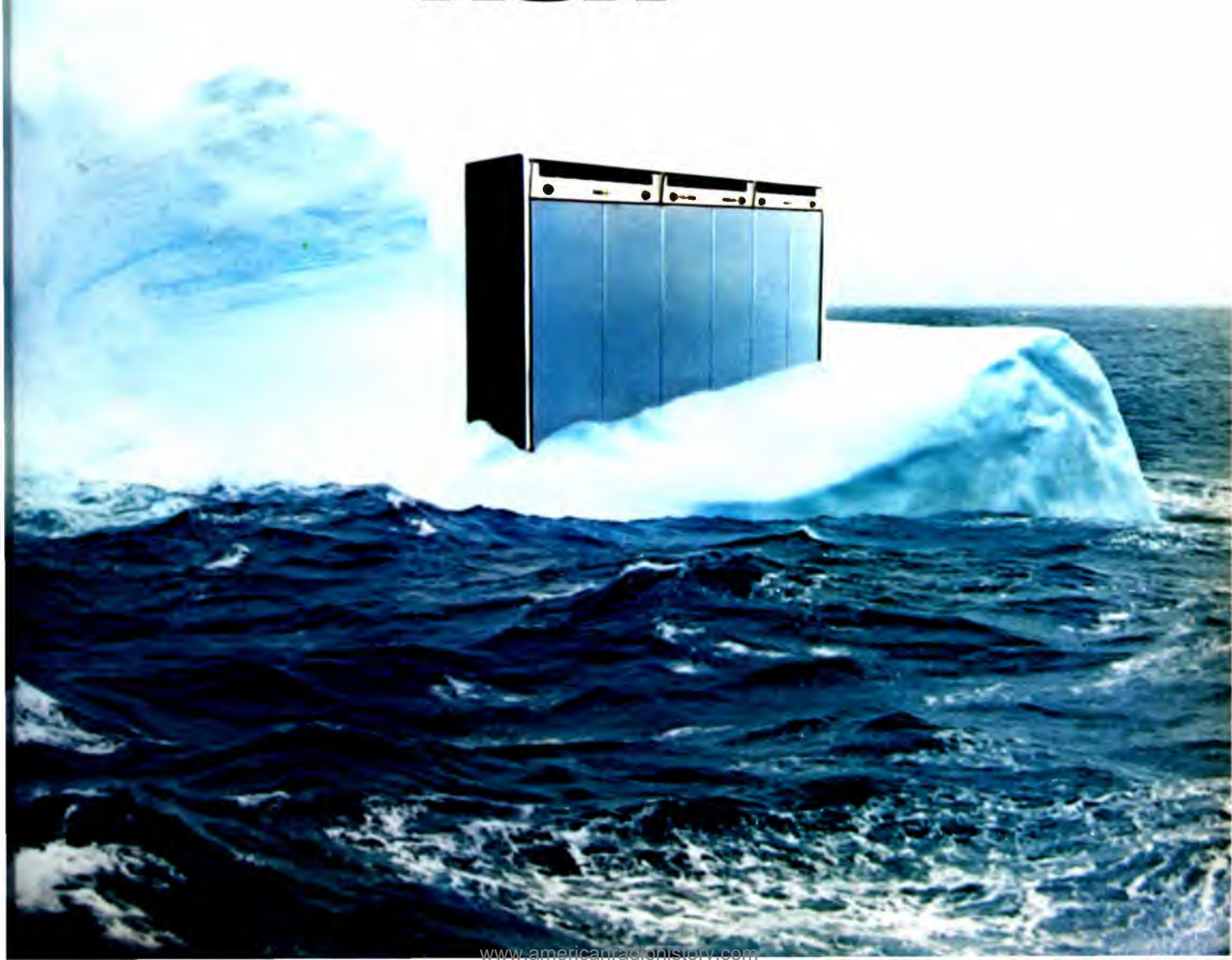

problems of radio and television—info from PLI at 1133 Sixth Ave., New York City.

Tracor, Inc., will market, under the Tracor label, spirometers made by Life Support Equipment Corp. of Woburn, Mass., for electronic measurement and early detection of lung disorders among employees in lung-hazardous environments . . . **NCTA** has made available "Complete Guide To Cable Marketing," transcript of second annual workshop. Cost is \$2.95 to members, \$4.95 to non-members, from NCTA at 918 16th Street N.W., Washington, D.C. 20006.

RCA dual 30-kW VHF television transmitters will go to Taft's WTVN-TV, Columbus, and WDAF-TV, Kansas City . . . **WITF-FM**, community-supported station in Hershey, Pa., has produced programs at several music festivals around the country for broadcast nationwide over the National Public Radio network.

Avantek, Inc. has two contracts with the U.S. Navy to supply over 600 solid-state amplifiers to replace existing TWT units . . . **Institute of Audio Research** will put on a four-day workshop in New York, November 15 through 18, on audio technology for

producers and arrangers, including studio technology, monitoring, session preparation, microphones, quad, etc.

Myers-Oak Communications Construction Co. of Crystal Lake, Ill., will build an 800-mile cable system for **Heritage Communications** to serve Des Moines, Iowa . . . **Hitachi Shibaden Corp.** will open an office at 14169 Proton Road, Dallas.

Broadcast Electronics, Inc., a subsidiary of Filmways, Inc. of Los Angeles, named Andrew Szegda as president, Ronald C. Lucas, executive vice president . . . **Central Design Corp.** is a new firm announced by David W. Hill, formerly vice president of Broadcast Products, Inc. The new firm, headquartered in Alexandria, Va., will market certain products of Broadcast Products and some of its own design.

Barton and Barton of San Francisco became Northern California and Nevada representatives for **Telex Corp.** . . . **Theta-Com** will receive a U.S. patent on the AML microwave local distribution system . . . **Anixter-Pruzan** will be a national distributor for Sony videocassette and studio equipment to the CATV industry.

Sterling Manhattan, cable franchisee in lower Manhattan, claimed the title of nation's largest single system, with over 61,000 subscribers in early fall of 1973 . . . **Gross Telecasting, Inc.**, multiple station owner, has agreed with

Federated Media, Inc. to buy station **WKJG-TV** in Fort Wayne, Ind., for about \$4 million, subject to FCC approval.

KOB, pioneer AM station in Albuquerque, N.M., is installing a **Gates MV-50**, 50-kW AM transmitter in a modernization program . . . **Video Cassette Industries** in Hollywood bought **Aldrich Studios**, historic plant where many famous movies were made, and will renovate the plant for all phases of video production.

Financial Briefs

Warner Communications Inc.: quarterly dividends payable November 15, of 10 cents on common, \$1.06-¼ on Series B convertible, 31-¼ cents on Series D convertibles . . . **Texscan Corp.**: first quarter to July 31: loss of \$27,410 on \$856,783 sales, attributed to training program, now complete . . . **Castle Industries**: quarter to July 28, sales \$1,870,500, profit \$139,600 (16 cents a share).

National Semiconductor Corp.: quarter to September 23, sales \$52 million, or 126% over 1972 period . . . **Lafayette Radio Corp.**: record sales and earnings for year ended June 30, 1973, of \$82,622,194 and \$3,983,867 respectively, before extraordinary items

. . . **Scientific-Atlanta**: sales sales
continued on page 75

**DATAVISION BRINGS YOU...
the great "one-liners"**



NBC photo—Dom DeLuise "Lotsa Luck"

We don't mean nifty patter like "take my wife, please take my wife". But, if you have a repetitive or non-changing message for video presentation, we can provide **one-liners** at remarkably low cost.

Model MG-1 Video Message Generator offers up to sixteen alpha/numeric characters per line for messages of your choice, such as...
PLEASE STAND BY!... HOTLINE BULLETIN... DON'T ADJUST SET...
TRANSLATOR TV 78... SPECIAL REPORT!... NEWS SPECIAL!

Model TT-1 is a Time and Temperature Video Generator; Model DT-1 is a Data and Time Video Generator. Time, temperature and date are easily reset from front panel controls.

FEATURES: ●CHARACTERS ADJUSTABLE IN SIX SELECTABLE SIZES 18, 36, 54, 72, 108 OR 144 SCAN LINES HIGH ●ADJUSTABLE DISPLAY POSITION ●LOCKS TO ANY SYNC OR VIDEO ●COMPACT, TAKES ONLY 1¾ INCH OF RACK SPACE.

For complete data, or a demonstration, call or write today.



DATAVISION INC. | 15932 Shady Grove Road
Gaithersburg, Maryland 20760
(301) 948-0460

Circle 112 on Reader Service Card

DYNASCIENCES

video products

Presents at

NAEB

1973

**Program Switcher
Editor Programmer
Auto Controller
Video Proc Amp**

**See us at Booth #1 and 2 for
demonstrations**

**DYNASCIENCES
CORPORATION**

video products

TOWNSHIP LINE ROAD, BLUE BELL, PA 19422

Telephone: (215) 643-0250 • Telex: 84-6358

Circle 113 on Reader Service Card

Need for Helical Standards Acute, Engineers Panel Says

IEEE Symposium also hears Goldmark ask for cable-satellite marriage; NQRC promises 1974 report.

A set of standards for helical VTRs is a hot potato all right, but some responsible body had better pick it up soon, a panel of engineers agreed at the 23rd Annual Broadcast Symposium of the IEEE, which ran at the Hotel Washington in Washington, D.C., on September 20 and 21.

The symposium drew IEEE members from across the country, with registration more than 15% above the 1972 total. The two-day program included more than a dozen technical papers on broadcasting and cable; luncheon addresses by Henry Goldberg, general counsel of OTP, and by Dr. Peter Goldmark of Goldmark Communications; and a progress report from the National Quadraphonic Radio Committee, presented by N.W. Parker of Motorola. The meeting was a bellwether in one general respect: it exhibited and furthered the intermingling of broadcast and cable engineers, and of broadcast and cable discussion topics, that has been growing at industry meetings for some time.

The panel on helical VTR standards, with Delmar Ports of NCTA as moderator, developed a strong consensus that the standards are acutely needed now. There was sentiment for different standards for the different main applications of VTRs—school, home, entertainment, cable, etc. Mr. Ports said we must keep in mind cable's potential for high-resolution, 10-MHz service, and also noted that the video disc may fill a complementary role. Blair Benson of Goldmark Communications pointed out that pay cable, in particular, was seriously hampered by the lack of interchangeability among video recordings. He noted the long list of characteristics that must be specified (more than 20 on tape dimensions alone), and asked for a joint effort of all responsible groups—IEEE, NAB, NCTA, SMPTE, etc.

But no such effort is in sight. Larry Janes, of Capital Cablevision, reporting on the work of the Cable Technical Advisory Committee in developing cable standards for FCC consideration, said that CTAC had been told by the FCC not to include VTR standards. It appears that the organized groups are not yet ready to tackle the political difficulties inherent in a set of helical standards.

Dr. Goldmark in his address reported that studies by his Goldmark Communications Corporation have indicated the technical and economic feasibility of his projected systems for bring-

continued on page 20

Paragraph 73.69 of the FCC's Rules and Regulations states:

... every standard broadcast station employing a directional antenna must use a type-approved phase monitor.



OUR AM-19 (204) IS THE ANTENNA MONITOR THAT MEETS ALL FCC REQUIREMENTS!

WHAT THIS MEANS TO YOU

1. If you're a new station or if you're making significant changes—you must have a type-approved antenna monitor by June 1, 1973.
2. If you operate your station with less than a first class radiotelephone licensed engineer, you must have a type-approved antenna monitor by June 1, 1974.
3. If you are presently operating your station by "remote control", you must have a type-approved antenna monitor Now! Or—you can use a monitor "properly configured", if such a monitor was manufactured after 1965.
4. Every other directional station must have a type-approved antenna monitor no later than June 1, 1977.

YOUR BEST CHOICE?

The AM-19 Antenna Monitor from POTOMAC INSTRUMENTS. The proven instrument for measuring phase and loop current ratio, the AM-19 can monitor up to 12 towers and accommodate DA-1,

DA-2 and DA-3 patterns. Phase meter resolution is 0.5 degrees. Loop current accuracy is $\pm 1.0\%$ with a 0.5% resolution.

AND—the AM-19 (204) is the only type-approved antenna monitor that meets all FCC requirements NOW!

YOU MUST HAVE A TYPE-APPROVED ANTENNA MONITOR—CHOOSE THE AM-19 (204) TODAY!

For complete information, please write or call:



Producers of
NEMO CLARKE
Broadcast Equipment

POTOMAC INSTRUMENTS, inc.
932 Philadelphia Avenue
Silver Spring, Maryland 20910
Phone: (301) 589-3125

Circle 114 on Reader Service Card

300 TV stations use it... The Gates PE-245 color film camera.

Accepted by five networks . . . in the United States, Canada and Mexico . . . as the finest quality film camera available.

The PE-245 color film camera together with the Kodak CT-500 TV projector with rapid channel threading film handling feature and the PF-12 multiplexer makes up the most modern, most dependable telecine system available anywhere. In addition, you get four-color projector inputs. Two color camera outputs. And split-island operation.

When you consider investing in a color TV film island, you want the system that'll provide the greatest versatility, the best performance and unquestionable dependability.

But don't take our word for it. Ask anyone who owns one. Then, make up your own mind.

HARRIS
 **GATES DIVISION**
Quincy Illinois 62301 U S A

Telecine center with PE-245 color film camera



REQUIRE ACCURACY?THEN BUY BELAR

MONITORS



The least you can afford is the best possible monitoring of your program material. The Belar TV Monitoring System (VHF or UHF) guarantees your getting what you need . . . accurately.

The Belar TVM-1 Modulation Monitor is the most accurate monitor available. Our advanced design starts where others leave off. TVM-1 Monitors both positive and negative modulation simultaneously and registers the higher of the two. Yes, it even tells you whether the modulation is positive or negative and calibration accuracy can be checked from the front panel modulation calibrator at any time.

The TVM-2 and TVM-3 Digital Frequency Monitors will measure TV visual carrier

and aural carrier independently or aural intercarrier. These monitors provide continuous monitoring with inhibited off-frequency alarm drivers, switch settable to either ± 500 or 1000 Hertz. It requires three successive errors to produce an alarm. This means *no* false alarms for you.

For remote control operations add the RFA-3 for off-air monitoring.

If your TV monitoring requirements include ease of operation, functional checks and ACCURACY, call or write today for more information. We know you'll make the right decision and BUY BELAR.



BELAR
ELECTRONICS LABORATORY, INC.

LANCASTER AVENUE AT DORSET, DEVON, PA. 19333
BOX 826 • (215) 687-5550

Where Accuracy Counts . . . Count On Belar

IEEE SYMPOSIUM

ing to rural communities the full range of education, entertainment, and culture available in cities. He said that satellites linked to local cable systems would play a major role, and he too emphasized the capability of cable for very-broadband, high-resolution service, a capability not available in the present system of broadcasting. The scheme was part of a proposal called "Ent-Sat" made by Goldmark Communications Corp. to the government, looking to the establishment of service to at least 50 towns by 1976, to help celebrate the country's bicentennial in that year. Among its elements are home receivers switchable from "standard" to "high resolution" programs.

The National Quadraphonic Radio Committee of the EIA is in full swing in its assessment of proposed systems for four-channel FM broadcasting, according to the report presented by Mr. Parker. The present plan is for completion of field tests early in 1974, with the final report to go to the FCC by mid-year if all goes on schedule. The report said that the "discrete" systems before the committee all use the sum of the four channels for the mono signal, although some introduce phase shifts. In general, differences among the "discrete" systems are relatively small, and consist in the main of placement in the spectrum of the various subcarriers, or in the modulation of the subcarriers—single or double-sideband, etc. As described in *BM/E* last month, six panels are at work, with Panel 1 to organize the field tests and collect all data into the final report. The subjective tests now underway by Panel 6 were due soon after this report was written to move from the West Coast to the East.

A number of the papers disclosed particularly interesting new technical developments, and *BM/E* hopes to publish summaries of several of them in future issues.

The program also included the presentation of two IEEE awards. The Vladimir K. Zworykin Award went to Dr. Albert Macovski of Stanford University for his contributions to single-tube encoded color cameras and color television receiving circuits." The Scott Helt Award went to Charles W. Rhodes of Tektronix for his recent papers on the use of vertical-interval tests in television and cable systems.

BM/E



A production console* for \$325.80!



Eureka! A complete remote and studio production console for a fraction of what you'd expect to pay for a console with comparable features and performance! Simply purchase a new *Shure M675 Broadcast Master* and the extremely popular *Shure M67 Professional Microphone Mixer*. By combining these two units*, you get inputs to handle microphones, turntables, phone lines and tape machines — *with cuing provision on line and magnetic phono inputs*. Result? A versatile low-noise, low-distortion broadcast production console for in-studio, remote, and standby assignments; a complete CATV console; a studio production console. All for \$325.80! For complete technical data, write:

Shure Brothers Inc.
 222 Hartrey Ave., Evanston, Illinois 60204
 In Canada: A. C. Simmonds & Sons Ltd.



*Each model is also available separately: M67 — \$169.20 net; M675 — \$156.60 net.

Circle 117 on Reader Service Card

Fraudulent Billing Practices

By Frederick W. Ford and Lee G. Lovett

Pittman, Lovett, Ford and Hennessey, Washington, D.C.

Introduction

The Commission, in what began as a revocation proceeding, recently ordered Station WLAS (Jacksonville, N.C.) to forfeit \$10,000 for violations of the rule against fraudulent billing.¹ The Commission considers violation of this rule to be especially serious because it involves the licensee in a fraud, thus raising serious questions as to his character and, hence, his qualification to continue as a licensee.

More than ten years ago, the Commission publicly decried the practice of fraudulent billing "as contrary to the public interest, and that appropriate proceedings will be instituted in all cases where evidence of double-billing by licensees is found to exist."² Subsequently, the Commission adopted Rules (applicable to AM, FM, and television broadcasters, respectively) which prohibit billing practices and released a "Public Notice" illustrating specific examples with which it was familiar.³ The Commission further strengthened the Rules by revising them to 1. clearly prohibit *any* form of false billing (misrepresentation), and 2. consolidate the three existing Rules into one, applicable to all three services.⁴

Fraudulent Double Billing

Prior to May 1970, the fraudulent billing rules were directed primarily to "double-billing" situations. The Commission noted that an essential element in "double-billing" is the furnishing of false information to any party contributing to the payment of broadcast advertising as to the amount actually charged by the licensee for such advertising or as to the nature, quantity, or content of such advertising.⁵

The Commission further presented examples of *known* "double-billing." In one such example, a station issued a bill to a local dealer for 50 commercial spots at \$5.00 each (\$250 total). At the same time, the station supplied the manufacturer of the products sold by the local dealer with another bill which indicated that the amount charged the local dealer for the 50 spots was more than \$5.00 per spot. This is fraudulent "double-billing" because it deceives the manufacturer, who receives the inflated bill, as to the actual amount received by the station for the advertising.

A second example: A station sends an invoice to a local advertiser for 50 commercial spots at \$5.00 each, indicating thereon that the spots were broadcast on behalf of cooperatively advertised products. The manufacturer receives a similar invoice, while in reality the local advertiser used some or all of the spots to advertise his store or other unrelated products for which coopera-

tive sponsorship could not be obtained. This constitutes fraudulent billing because, by falsely representing that the spots advertised certain products, the station is enabling the local advertiser to fraudulently receive payment from the manufacturer for advertisement of its product which had never really been broadcast.

One essential element of fraudulent "double-billing" is "knowledge" or "lack of due diligence" on the part of the station. Thus, a situation could arise in which a station gives 50 bonus spots to a local advertiser who had previously bought 50 commercial spots at \$5.00 each (\$250 total). The local advertiser uses the bonus spots to advertise his own store without informing the manufacturer that the local advertiser received the benefit of 100 spots. An invoice sent to the manufacturer citing 50 cooperative spots costing \$250 is fraudulent "double-billing" if the local advertiser entered the original agreement to air 50 spots with the understanding that 50 bonus spots were part of the same transaction. If, on the other hand, the station had no knowledge that the local advertiser attempted to deceive the manufacturer in this situation, then the station is not guilty of fraudulent "double-billing."

Although most "double-billing" is designed to deceive and defraud manufacturers into paying a larger share of a local dealer's cooperative advertising expenditure than that originally stipulated in agreements with local dealers, some manufacturers have reimbursed a dealer for a cooperative advertising bill which the manufacturer *knew* to be inflated or fictitious. Such a scheme violates the Clayton and Robinson-Patman Acts.⁶ These Acts make it unlawful for a manufacturer or distributor engaged in commerce to give discriminating discounts, rebates, or advertising allowances to its dealers. If such violations are found to exist, the Federal Communications Commission will refer its findings to the Federal Trade Commission for appropriate action.

Fraudulent Billing Rule

As previously stated, the Commission expanded the "double-billing" rule to cover *all* instances of fraudulent billing. The amended rule (Section 73.1205) reads as follows:

Fraudulent Billing Practices—No licensee of a standard, FM or television broadcast station shall knowingly issue to any local, regional or national advertiser, advertising agency, station representative, manufacturer, distributor, jobber or any other party, any bill, invoice, affidavit or other document which contains false information concerning the amount actually charged by the licensee for the broadcast advertising for which such bill, invoice, affidavit or other document is

continued on page 24

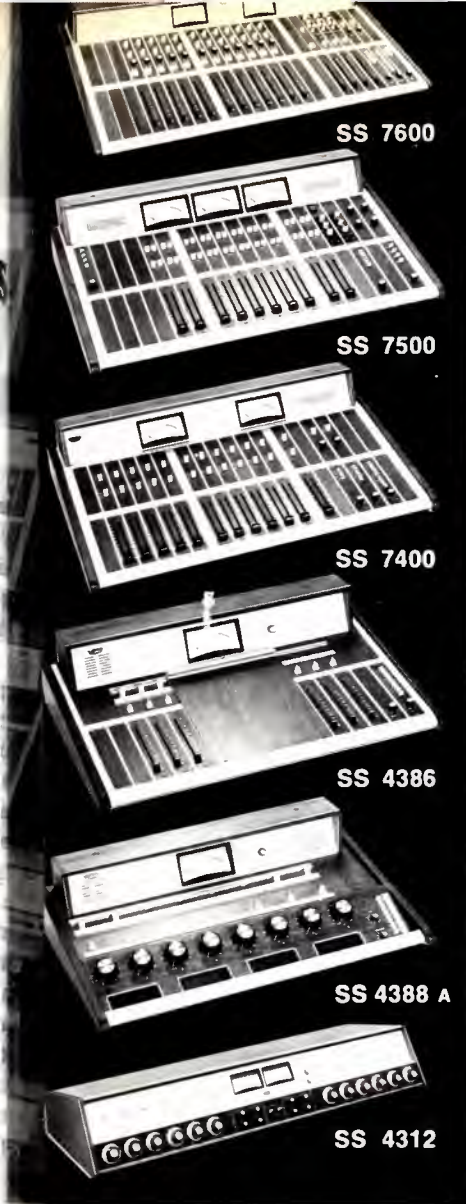

**Stereo package shown:
2 SS 3158 turntables, 1 SS 7500 console, 1 SA 10044 cartridge
tape housing, 1 SA-10041 reeltape housing & ITC tape equipment.**

Here's the McCurdy Package...with options

The McCurdy package approach to the engineering of a system allows the user to easily determine the best selection of standard components to fulfill his requirements.

All aspects of the broadcast function from news booth to full TV or record production can be met with the minimum of interface between units. A full range of furniture allows for the integration of each part of the system into the most convenient working package.

Optional components including disc reproducers, reel tape housings and cartridge tape housings designed for instant operational accessibility, combine with any of the consoles shown to fulfill the basic needs of the broadcaster.

Each system is fully pretested as a total unit and will meet or exceed all broadcast specifications.

McCurdy Radio Industries Inc.

1051 CLINTON ST., BUFFALO, N.Y. 14206 TELEPHONE (716) 854-6700

108 CARNFORTH ROAD, TORONTO, ONTARIO M4A 2L4
TELEPHONE (416) 751-6262 TELEX 02-21660

Circle 118 on Reader Service Card

AUDIO AND VIDEO

**NEW
AVM
8000 Series
'STATE OF
THE ART'
ROUTING
SYSTEMS**

by

**RICHMOND HILL
LABORATORIES
INC.**

142 Central Avenue,
CLARK, NEW JERSEY, 07066

NEW JERSEY
142 Central Avenue,
CLARK, NEW JERSEY 07066
(201) 381-5955

WASHINGTON
Riggs Road at First Place N.E.,
WASHINGTON D.C. 20011
(202) 882-2525

CANADA
1240 Ellesmere Road,
Scarborough, Ontario
CANADA M1P 2X4

U.S.A. DISTRIBUTORS
Telemation Inc.,
P.O. Box 15068
Salt Lake City,
Utah 84119



Circle 119 on Reader Service Card

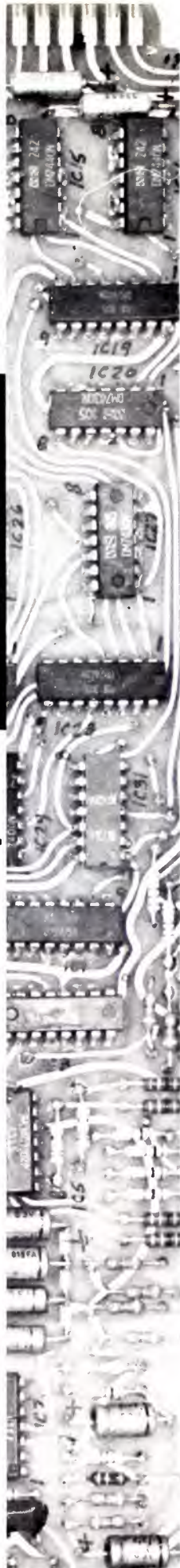

FCC Rules & Regs

issued, or which misrepresents the quantity of advertising actually broadcast (number or length or advertising message) or the time of day or date at which it was broadcast. Licensees shall exercise reasonable diligence to see that their agents and employees do not issue any documents which would violate this section if issued by the licensee.

Thus, the Commission prohibits the "knowing rendition" of any bill or document which misrepresents 1. the number of announcements which the station runs, and/or 2. the character, length, date and time of the announcements actually broadcast.

The rationale for imposition of these additional prohibitions is clear. Misrepresentation of the number of announcements actually run may give rise to the fraudulent "double-billing" of an unwary manufacturer. Moreover, the character, length, date and time of commercial announcements broadcast are matters of vital interest to all manufacturer-sponsors. Such sponsors are paying the advertiser to reach the viewing audience most receptive to the product advertised. Misrepresentation of broadcast time, date, and character are likely to foil the manufacturer-sponsor's efforts to reach his desired audience. Such misrepresentations may act to defraud him of the benefits for which he is paying, i.e., broadcast exposure to the maximum-size audience receptive to his product.

Following are two examples of "other" (besides "double-billing") fraudulent billing practices.

1. A station knowingly issues a bill or invoice to an advertiser which states that X number of commercial announcements were broadcast at 9:08 p.m. on a certain date. The announcements were actually broadcast at 9:08 a.m. This is fraudulent billing since the time of broadcast in this case is critical in its value and the price charged, i.e., a substantially larger prime-time viewer audience (assuming *arguendo* that the only critical criteria is audience size).

2. A station issues a bill or invoice to an advertiser which correctly states the character, number, date, and time of a commercial announcement broadcast, but misrepresents the 45-second commercial as a 60-second commercial. This is fraudulent billing since the station misrepresents commercial length, a highly important element of the price charged for commercials.

Network Program Clipping

"Clipping" of network programs may give rise to violation of the fraudulent billing rule if the clipped material contains commercial matter.

Clipping may arise under a variety of circumstances, including: 1. discontinuation of a network program broadcast before the program's completion; 2. joining of network programs after they have begun; and 3. expansion of station breaks within network programs, resulting in a failure to carry such programs in their entirety (and then *falsely* representing to the network that each program was broadcast in its entirety).

When the clipped material contains commercial matter (as contained in the "crawl" at the end of certain quiz or game shows⁷), and the station falsely certifies that the network program has been carried, the station has violated the fraudulent billing rule.

Clipping of network programming that does *not* contain commercial matter means that the station has not fulfilled its contractual obligation to the network. A station's false certification that the complete network program has been broadcast gives rise to fraud.

Thus, clipping of commercial or non-commercial net-

the first reel to reel with the rugged reliability of **itc**



Exclusive, but optional, is the micro-mark tape marker to make editing easy and precise. Find the critical spot in the tape, press the button, and the tape is marked clearly and accurately. Who would have thought of it but ITC?

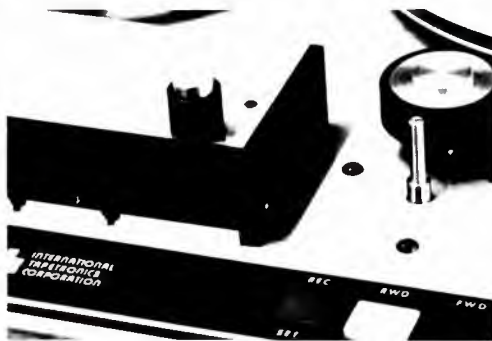

After years of concentration on building the finest tape cartridge equipment, it was inevitable that ITC would design a reel-to-reel machine with the rugged reliability that is inherent in the International Tapetronics' name. And here it is . . . incorporating all those features most wanted by broadcasters. Examples: motion sensing, multi-function edit mode, ITC's proven air damped solenoids for super quiet operation, automatic tape lifters, TTL logic circuitry, capability of handling dissimilar size reels, selective play/record synchronization, 10½" or 14" reels, 3¾ - 7½ IPS or 7½ - 15 IPS and the superior specifications you'd expect.

Some of our customers are buying sight-unseen because of our reputation for dependable performance and service. Our standard procedure is a 30 day guarantee of satisfaction in addition to a one year warranty. Just call us collect and say you want to try the new ITC "850" Series. We'll make all the arrangements.

Phone number 309-828-1381.



INTERNATIONAL TAPETRONICS CORPORATION

2425 South Main Street • Bloomington, Illinois 61701

Marketed exclusively in Canada by McCurdy Radio Industries Ltd., Toronto

Circle 120 on Reader Service Card

FCC Rules & Regs

work programming matter is to be avoided, *except* in the following cases:

1. The broadcast station's discretion to delete indecent, profane, obscene, or bad taste programming is *not* restricted. Indeed, the broadcaster has an affirmative duty to conform programming to the public interest.

2. Occasional clipping of only a few seconds duration is not prohibited, if caused by technical or switching problems.

In either of the preceding exceptions, the broadcaster would be well advised to notify the network (and the advertiser, if clipping of commercial matter is involved) to obviate further problems.

Sanctions

Violation of the fraudulent billing rule may carry harsh sanctions—ranging from stiff forfeitures to revocation proceedings.

In one case, a \$10,000 forfeiture was imposed upon a station which clipped network programs that included announcements disclosing the receipt of payment for the use of merchandise on the programs.⁸

In another case (cited in the introduction), a revocation proceeding was instituted against a station which violated the Commission's fraudulent billing rule. Although the proceeding was dropped, the station was ordered to forfeit \$10,000.

Violation of the fraudulent billing rule may also haunt the broadcaster during license renewal proceedings. In one recent case, opponents to a license renewal application nearly succeeded in bringing the licensee's basic qualifications into issue by surfacing evidence of past

fraudulent billing and network clipping violations of the licensee's other stations. Evidence of the prior violations was allowed into issue on a comparative basis, thus jeopardizing the licensee's renewal chances.⁹

Conclusion

Violation of the Commission's fraudulent billing rule may occur because of 1. traditional fraudulent "double-billing," 2. "other" fraudulent billing, and 3. network program clipping.

Through a series of "Public Notices," the Commission has clearly defined fraudulent billing practices and has provided detailed examples of such violations. Because of the fraud involved, violation of this rule is considered serious.

Moreover, because of "character" issues raised (and, hence, the licensee's qualifications to remain a licensee), the Commission has further announced that it intends to closely scrutinize fraudulent billing cases.

Broadcasters should not hesitate to consult with their communications counsel should questions arise concerning this vital issue.

BM/E

¹ *Seaboard Broadcasting Corp.*; Docket No. 18814 (1973).

² *Public Notice*, 23 RR 175 (1962).

³ *Public Notice on "Applicability of Fraudulent Billing Rule,"* 6 RR 2d 1540 (1965).

⁴ *Memorandum Opinion and Order*, 19 RR 2d 1506 (1970).

⁵ *Memorandum Opinion and Order*, *supra*, at 1507.

⁶ 15 U.S.C. 13

⁷ Note that a commercial announcement includes certain "sponsor identification" and "receipt of payment" announcements pursuant to §317 of the *Communications Act*.

⁸ *Channel 13 of Las Vegas, Inc.*, 25 RR 2d 286 (1972).

⁹ *Western Communications, Inc.*, 26 RR 2d 1659 (Rev. Bd. 1973).

THE BEST



And because that's the way things are, the EMT-930st is also the most expensive turntable you can buy.

In the short run.

In the long run, you'll own precision-made equipment that really slashes maintenance costs, because it's virtually trouble-free. For years. Ask anyone.

Other features? Low rumble; $\pm 0.035\%$ rms ANSI flutter; and you can cue to any beat or syllable with a wow-free start from the world's only remote-controlled turntable.

You pay for what you get. And here, you get the winner.

For more information, write

GOTHAM
AUDIO CORPORATION

Headquarters: 741 Washington Street, New York, NY 10014

(212) 741-7411

West Coast Sales Office: 1710 N. LaBrea Ave., Hollywood, CA 90046

(213) 874-4444



THE SECOND BEST

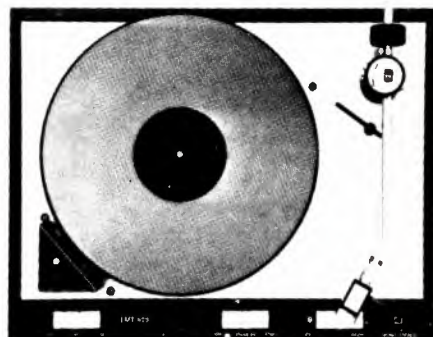

We won't kid you.

The EMT-928 doesn't have all the ruggedness of our friend across the way.

On the other hand, the EMT-928 costs 40% less.

And it's self shock-mounting, so that you can drop it into an existing console desk. Also, it has a front panel speed adjustment trimmer our "neighbor" doesn't have.

A proven concept augmented for professional use, the EMT-928 stands second to none in construction, durability, and performance. Except for you know who.

Well, we can't win 'em all. But you can. Just take your choice.

For more information, write

GOTHAM
AUDIO CORPORATION

Headquarters: 741 Washington Street, New York, NY 10014

(212) 741-7411

West Coast Sales Office: 1710 N. LaBrea Ave., Hollywood, CA 90046

(213) 874-4444



Circle 121 on Reader Service Card

The ASACA ACC 5000 Color TV Camera

BREAKS the PRICE BARRIER!



The 1st truly portable
TV Color Camera
that meets exacting
BROADCAST
standards

...and sells for \$32,000.

The ACC-5000 Portable Color Television Camera System is a light weight compact video pickup system developed for high mobility and fast on-site reporting. This camera and back pack combination provides a perfect high quality NTSC (composite) output.

The ASACA Camera makes Color TV programming a reality for every segment of the communications marketplace.

BROADCAST • CABLE • EDUCATIONAL • MEDICAL • INDUSTRIAL

Ultra-compact light weight camera head design for convenient operation and handling.

Excellent mobility for relay broadcasting, on-site news reporting and interview duties.

Full complement of self-adjusting features; color adjustment is extremely easy and set-up time minimized.

The perfect NTSC signal output permits direct connection to a VTR without going through a base station.

Genlock capability via external sync allows parallel camera operation and centralized control.

Camera can be powered by either a regulated power supply contained in the control box (installed at the base station) or battery voltage

Learn more about the ASACA ACC 5000 and what it can do for you. Contact our nearest office TODAY.

Exclusive U.S. Distributors

SOS Video Equipment

315 West 43rd Street, New York, N.Y. 10036 • (212) 586-1420
7051 Santa Monica Blvd., Hollywood, Calif. 90038 • (213) 469-3601

A DIVISION OF F&B/CECO INDUSTRIES, INC.

Circle 122 on Reader Service Card

AMPEX MAKES THE WORLD'S BEST
AMPEX MAKES THE WORLD'S BEST
AMPEX MAKES THE WORLD'S BEST
AMPEX MAKES THE WORLD'S BEST
AMPEX MAKES THE WORLD'S BEST
AMPEX MAKES THE WORLD'S BEST
AMPEX MAKES THE WORLD'S BEST

FULL COLOR VIDEOTAPE TELEPRODUCTION
CAPABILITY IS WHAT MAKES THE AMPEX
VPR-7950 THE WORLD'S BEST \$40,000 VTR.

When you have to put together sophisticated, broadcast-quality teleproductions in full color, the Ampex VPR-7950 has everything you need.

Because the VPR-7950 is Hi-Band (7-10 MHz), your broadcast or cable originations, as well as your multi-generation dubs, will be amazingly true.

D.O.C., Vel Comp and processing amplifier modules increase picture quality even more, to satisfy the discerning professional.

And because the VPR-7950 has an integral Time Base Corrector, the signal will meet or exceed full FCC/CCIR broadcast specifications for both monochrome and color material.

Ampex packages the VPR-7950 in both low-boy and overhead monitor consoles, with a choice of optional video waveform and picture monitors and vector display. Order the complete package, and you'll be in the broadcast production business; ask for fewer options, and you'll find a happy

fit with most industrial requirements *and* budgets.

The best way to test our claim is to ask for a demonstration. Contact your nearest Ampex Sales Office or Ampex headquarters in Redwood City — we'll relay the message.

Ampex makes the world's best videotape recorders.

100,000 VIDEOTAPE RECORDER.
75,000 VIDEOTAPE RECORDER.
50,000 VIDEOTAPE RECORDER.
40,000 VIDEOTAPE RECORDER.
22,000 VIDEOTAPE RECORDER.
16,000 VIDEOTAPE RECORDER.
2,600 VIDEOTAPE RECORDER.



AMPEX

Ampex Corporation, Audio-Video Systems Division, 401 Broadway, Redwood City, CA 94063 • (415) 367-2011

Canon offers the perfect zoom lens for the camera of your choice



More and more people are discovering how significantly superior Canon Zoom Lenses are for TV broadcasting purposes. Their outstanding color characteristics, even in dim light, is one of the many reasons why Canon was chosen for telecasting the Munich Olympics. Canon's wide range of excellent zoom lenses encompass three types of operation control— all-servorized, via flexible cables and by effortless push pull rod control. And it can be attached to

fit and operate with any make of TV camera. Shown on this page are only a few examples of the quality lenses Canon has available to more than meet your particular demands. Specify Canon to stay ahead.

The following are Canon TV Zoom Lenses for the Plumbicon® color cameras currently available on the market:

Size of image tube	Lens	Image format covered
1 1/2" Plumbicon® color camera	P10 x 20B4	17.1 x 12.8mm (21.4mm ϕ)
	P17 x 30B1	
	P17 x 30B2	
1" Plumbicon® color camera	PV10 x 16B1	12.8 x 9.6mm (16mm ϕ)
	PV10 x 15B2	
	PV17 x 24B1	
	PV 6 x 18B1	

® Reg. TM N.V. Philips of Netherlands

The Canon TV Lenses Naming System



Applications	Image Format	Pick-up Tubes
P	21.4mm ϕ	1 1/2" Plumbicon
PV	16mm ϕ	1" Plumbicon

Apart from the above, Canon has available TV zoom lenses for 3" or 4-1/2" image orthicon cameras and can also build special lenses to fit your requirements.

Canon

● CANON INC. 4-1-1, Ginza 5-chome, Chuo-ku, Tokyo 104, Japan ● CANON U.S.A. INC. 10 Nevada Drive, Lake Success, Long Island, New York 11040 U.S.A. (Phone) 516-488-6700 ● CANON U.S.A. INC. 457 Fullerton Ave., Elmhurst, Illinois 60120 U.S.A. (Phone) 312-833-3070 ● CANON OPTICS & BUSINESS MACHINES CO. INC. 3113 Wilshire Blvd., Los Angeles, California 90005 U.S.A. ● CANON AMSTERDAM N.V. Gebouw 70, Schiphol Oost, Holland ● CANON LATIN AMERICA, INC. Apartado 7022, Panama 5, Panama

Circle 123 on Reader Service Card

A new generation of PBX's from the Bell System.



Your business's Private Branch Exchange (PBX) is the basic component of your communications system. Now the Bell System has a new family of PBX's.

These new PBX's are neatly housed in compact cabinets. They are designed for modular growth, with plug-in expansion features. They can handle up to 2000 phones. Because the consoles of the new units are push-button operated, training new operators is a snap.

In addition to such basic services as interoffice dialing, each PBX offers many options. Like "station add-on" that lets you add a third person to a call. And "attendant camp-on" that lets your operator route an incoming call to a busy phone, and automatically connects it when the extension is free.

When you choose one of our PBX's, you get dependable Bell System maintenance, available locally. For more information, call your Bell Communications Consultant. We know your business communications needs keep changing. Our new generation of PBX's keeps pace.

We hear you.



Astral[®]. There isn't a dimmer around that costs more because they're all worth less.

No wonder Astral dimmers are used by important TV studios and theatres such as the one that produces Sesame Street and The Electric Company. As well as by See Factor for all their rock shows.

Astral 2, 3, 6, and 12 kw dimmers are the best because they create no RFI to disturb audio or video. What's more, all adjustments and test points are on the plug-in, front accessible logic card.

And who else offers a standard 19" chassis featuring all aluminum welded construction. Plus a maximum height of 7" on our largest unit. So even though Astral is more expensive to buy it's much less expensive to rack.

To further demonstrate Astral's value we'd like you to have a complete set of comprehensive specs; something no one else dares to offer. For your copy, write or call us today.



**SKIRPAN
LIGHTING CONTROL
CORPORATION**

41-43 24TH STREET / LONG ISLAND CITY N.Y. 11101 212-937-1444



Circle 125 on Reader Service Card

A DEAD MIKE DOESN'T HAVE TO BE A DEAD LOSS.

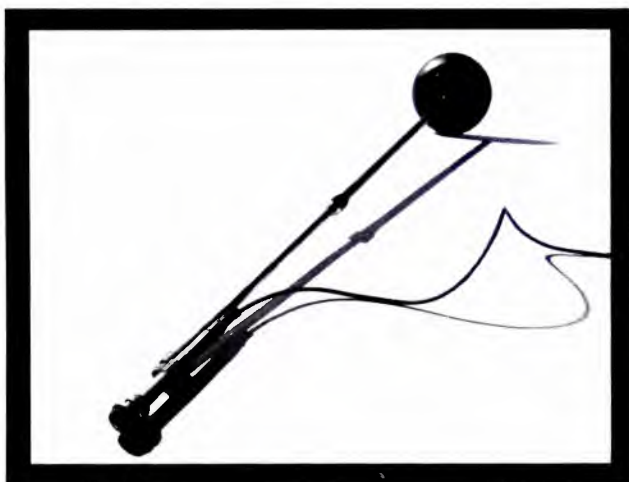

Ask any radio or TV station operator who has depended on American Home over the years.

He'll tell you:

American Home's program of insurance protection is as advanced as the industry's own equipment.

It includes All Risks coverage against direct physical loss or damage of the station's building and tower. Its antennas. Its cameras. And all other operating equipment.

American Home also writes insurance protection that moves outside with the industry—covering mobile vans, portable sound systems, and other equipment used in remote broadcasts.

But that's not all:

American Home knows that damaged equipment is bad enough. Loss of air time is even worse. So we offer a Business Interruption policy that protects the station against loss of broadcast revenues in such cases.

We'll shape each policy to fit the station's own needs—with rates that reflect the individual exposure, and deductibles that make sense.

And we'll do one more thing:

Because our experience in protecting the communi-

cations industry goes back almost as far as KDKA, we can offer some practical engineering recommendations that will improve the risk, and may save you money.

Send the coupon today, and we'll tell you more.

American Home Assurance Company

Dept. BG 113, 102 Maiden Lane, New York, N.Y. 10005

Please send me more information about your Broadcast Equipment Floater coverage.

Name _____

Title _____

Company _____

Address _____

City _____ State _____ Zip _____



A Member Company of
American International Group

We welcome inquiries from any licensed agent or broker. You don't have to be a regular producer to place business with American Home.

Circle 126 on Reader Service Card

Audio Processing for Diverse Programming

By James A. Zinser

WGPR-FM, Detroit, puts on a variety of music and talk shows, many remotes, a lot of recorded music. A corresponding variety of audio processing techniques was needed for optimum handling of each program.

One of the prime concerns of practically every FM broadcast engineer is getting optimum performance from the various audio processing devices. Usually the engineer's decision as to correct operation of this equipment is based partly upon knowledge drawn from past experience and partly upon what the "book" says is right. A third consideration is often overlooked: the relation of the station's programming to the operation of AGC and limiting equipment.

This last consideration took on special emphasis for our organization when we set out to rebuild the facilities of WGPR-FM, which serves Detroit's black community with a wide variety of program types. A typical day may include studio or remote-originated music shows, unattended remotes from a number of area churches, disc jockey remotes, telephone talk programs, plus a number of taped programs. Station management wanted the best sound possible from any program source plus relative ease of operation for its personnel. This in turn placed a number of burdens upon the ultimate audio processing equipment configuration.

We developed a semi-automated easy-to-maintain broadcast facility that employs a total of eight AGC or limiting devices. At first, this profusion of audio processing equipment may seem to be a needless extravagance, but once the operational philosophy of the station is understood, the need for each unit becomes clear.

Fig. 1 is a functional block diagram of WGPR's audio chain. As can be seen, the station utilizes three basic groups of input facilities: dial-access remote broadcast switchers, two studios, and an input-bridging switcher. Each group has its own AGC equipment.

For Studio A, the station's main control room utilizes a fairly conventional set-up to facilitate the programming of disc-jockey type music shows in stereo. Inputs from microphones, turntables, and cartridge machines are routed through the Altec console to the two CBS Audimax leveling amplifiers. Since this studio is used for virtually all station-originated music shows, we set up the associated AGC equipment in the "classic" manner. For a standard program level of +8dBm (0 VU on console meters) the Audimax units supply a unity gain output, neither compressing nor expanding the signal. The units act on the audio only when the level deviates substantially from this norm. This approach offers optimum reproduction of music with minimum distortion of the dynamic range due to the relatively slow attack time

of the Audimax when used in this manner.

It should be emphasized that this classic set-up is not desirable for all music stations. One rock station built and maintained by ASI, for example, uses a totally different approach. The station's audience is primarily made up of teenagers and pre-teens, listening on small pocket FM radios or FM car radios. It was decided, therefore, that dynamic range could be sacrificed for an increase in the station's apparent loudness. This station's leveling amplifiers are set to provide some compression even at normal program levels. This keeps the average modulation percentage of the transmitter very high, providing all the well-known advantages including high apparent "loudness."

Another feature of this approach is that a certain amount of artificial expansion of the signal results. While we don't normally think in terms of a compressor being capable of expansion action, in practice this actually is the case. When the unit is adjusted to give a "normal" program level enough compression to bring the signal down to unity gain, a signal coming into the unit at less than normal level won't be compressed at all. The lower level signal will cause the unit to return to a point at or near unity gain. Thus the gain of the low level signal will be increased toward unity and an artificial expansion will result.

Because of the Audimax's fast attack time when adjusted in this manner, there will be an increase in the well known "pumping" effect that is a characteristic of all compression devices. Therefore, a careful analysis of the station's format and audience, as well as its competitive position in the market, should be undertaken before the decision to use this system is made.

At WGPR, we chose dynamic range over high output for Studio A after it was determined that a large number of its audience listened to the station on high-quality systems. Further, the station's unique format of diverse music styles plus talk and religious programming made extra apparent loudness unnecessary for competitive advantage.

Studio B, however, was an entirely different matter. This studio is a mono-only facility and is used primarily as a production studio. It also serves as the on-air studio for the station's telephone talk shows. Because of this, and because the station prefers to record its spots without production music in most cases, a wide dynamic range for this studio was deemed unnecessary. Using some compression at all times gives talk shows the same advantages already outlined for rock music formats. Therefore, the single CBS Audimax fed by Studio B was

Mr. Zinser is vice president, marketing and advertising, Audio Services, Inc., Southfield, Mich.

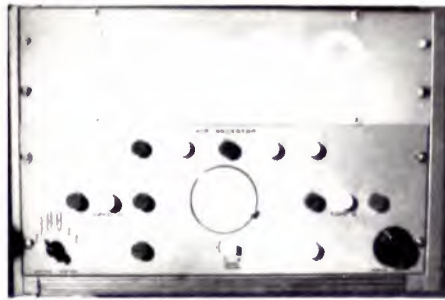

Close-up of dial access/digital readout unit in Studio B

adjusted to give approximately 3dB of compression at a standard program level of +8dBm. This helps overcome telephone line noise and improves the intelligibility of phoned-in comments.

Of course, the station utilizes the usual nine-second delay unit between the Sparta console and the Audimax to prevent objectionable material from being broadcast. The show host need only push a button and the output of the delay machine is instantly removed from the line. Simultaneously a "fill cart" is started in another machine and its output is fed to the line. The cart contains a station and program promotional announcement which is also nine seconds in length. Thus there is no dead air while the delay cart is advancing past the objectionable material. At the end of nine seconds the fill cart machine's output is removed from the line and the output of the delay machine returns.

Console, delay, and fill cart machine outputs are all adjusted to maintain +8dBm on the line to the Audimax AGC. Thus, all of the Studio B audio sources receive the benefit of the 3dB compression provided by the Audimax unit. As was mentioned earlier, this studio is also utilized to record the station's voice-only spots. The inputs to all recording equipment, be it reel, tape, or cartridge, is fed from the output of the Audimax. Thus all recorded material is preleveled as it's recorded.

This results in a greater audio "punch" for the spots when they go on the air from Studio A, or through the carousel units described later in this article. By maintaining a high average recording level via AGC, a higher average modulation level is attainable upon playback, making the spots stand out on the air, just as though the AGC units associated with Studio A or the carousel were adjusted momentarily for high compression rather than



Dial access switch located on master console controls reel-to-reel, carousel, and remote broadcast lines.

for music reproduction.

A second benefit of compression during the recording of spots is that a better S/N ratio is obtained over the inherent tape which is found in all magnetic recording devices. It should be emphasized again that what we've outlined above is one approach among many. For example, we would not recommend constant compression for a station that uses its production facilities to cart all of its music, or that uses a large amount of musical material in its spots, especially if the station places a premium on quality music reproduction. But, if you're an all-talk station or you do voice-only spots, extra audio punch like that in WGPR's Studio B, via AGC, might be just the ticket for you.

Referring again to the block diagram, you'll note two dial access switchers. These units were designed by ASI's custom systems department as a practical means of solving WGPR's staggering remote broadcast load problem. There's no misprint on the diagram: The station actually does broadcast up to 40 remotes a week. Up until we rebuilt the station, remotes were handled through a maze of selector switches and clip leads. If the operator was lucky, he just might find the right cable pair for the remote he needed.

The dial-access switchers have solved this problem quite well. They're versatile and easy to operate, thus cutting down the amount of time necessary to accommodate remotes. Needless to say, they also eliminate the technical clutter and the resulting reliability problems. The remotes associated with these switchers are, for the most part, of the "unattended" variety, with microphones, remote amplifiers, and phone lines installed at the remote site (usually a church, in WGPR's case). They are merely turned on before the broadcast starts—no engineer is on hand at the remote location.

Since this type of program needs no assistance from operators or announcers back at the studio, it was decided that the switchers should have the capability of feeding the dial selected remote not only to the consoles in Studios A and B, but also directly to the transmitter via AGC processing, once the remote program is introduced by the station's announcer, and brought up on the air through one of the two consoles. The operator merely pushes a button and the remote goes to the transmitter directly. This frees both consoles for production duty during remotes. The switching from one mode to the other is virtually undetectable over the air. It's noiseless and causes no detectable level change.

While this approach to remotes allows the station great flexibility in its use of equipment and personnel, it causes other problems. The combination of riding at the remote, with the unpredictable levels of phone company facilities, created a real challenge to stable AGC operation. To compensate for the varying phone line levels, an ASI-designed automatic attenuator system is used ahead of the two specially modified Gates AGC amplifiers to bring the line up to a usable AGC level. This is accomplished via solid-state modules utilizing control signals obtained from the AGC amplifiers themselves. The modules, in turn, drive the servo-controlled attenuators inserted in the line.

For this type of remote, a constant compression level of 7dB was selected. This operating point offers enough compression to be useful, but not enough to cause noticeable "pumping." This level also provides the artificial expansion effect already discussed.

The entire leveling process is initiated automatically simply by dialing up the remote a few minutes before broadcast. Participants in remotes are instructed to put a test signal on the line five minutes before air time for this purpose. The second switcher is identical to the first and is utilized to select and set levels on a second remote while the first is still on the air. Its output is then put on the air at the appropriate time, while the unit is then used to prepare a third remote for broadcast.

In operation, both switchers operate as one since the same dialing mechanism is used to operate both units. This reduces operator confusion and makes for a neater appearance. A large digital readout is used to indicate which remote is on the air and which is in the standby mode ready for broadcast. These dial/readout units are located in each studio so the system can be operated from either position.

Here again we don't recommend a 7dB compression level for everyone who might want to employ limiting techniques similar to ours. Such a decision must be made based upon your own particular needs. However, 7dB is a good starting point.

WGPR's final audio input group is the bridging input switcher and its associated equipment. The switcher designed by ASI is probably the most unique audio handling device at the station. It allows complete random access to the station's two carousel cartridge players as well as total control of the two reel-to-reel machines and a conventional cartridge machine. This is accomplished via the same dial/digital readout unit utilized by the remote switcher. The operator just dials the number of the cartridge he needs. When the cartridge is moved into position by the carousel unit, its number is displayed on the digital readout to confirm system readiness, and as a double check on proper cartridge selection.

The output of this unit can be brought up on the air at the touch of a button through either console or fed directly to the transmitter through its own AGC system. The reason for this latter option is twofold. First, complete taped programs can be played through the system on the reel-to-reel machines without tying up the two consoles. Second, the most unusual feature of the system—when the station does a disc jockey type of remote, a special dialer/readout unit is installed at the remote location. This gives the air personality complete control of the carousel and reel-to-reel equipment back at the studio with the touch of a button. It also eliminates the need for a studio "producer" to play carted spots for the man on remotes as well as the alternate approach of taking cartridges and machines to the remote site. An additional benefit is that, once again, both consoles are freed for production use during this type of remote.

Because of this option for putting the switcher output directly on the air, it was decided that this unit too should have its own AGC system. A CBS Audimax is adjusted to give 3dB of compression at a normal input level of -10 dBm. This constant compression is necessary to achieve a reliable measure of control over the levels on tapes supplied by outside sources. Many of the station's pretaped programs are produced by churches and other community organizations who often lack both professional equipment and professional recording personnel. Therefore, compression is needed for adequate control over the levels on this type of program.

As you'll recall from our discussion of Studio B,

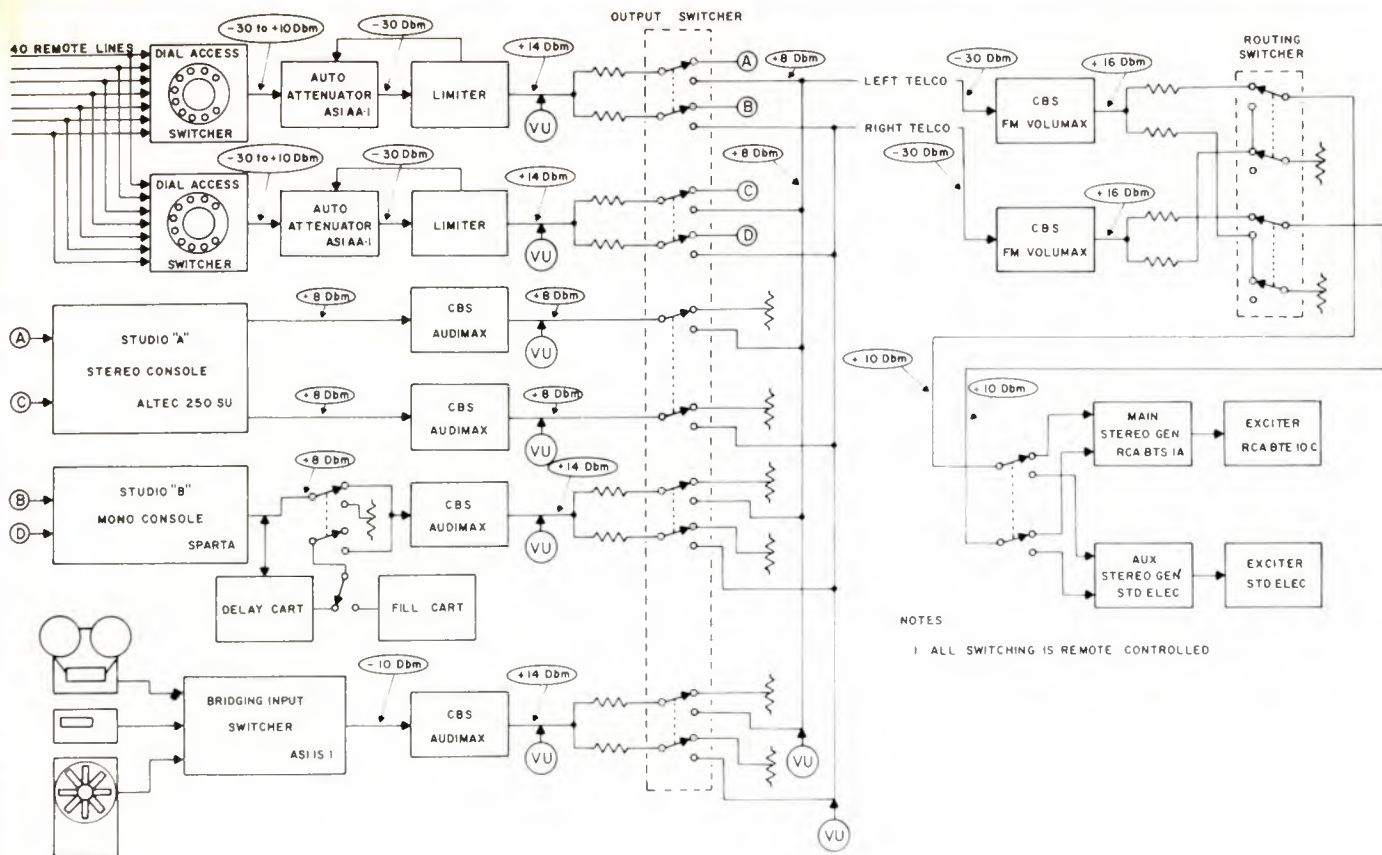

Fig. 1. Block diagram of signal flow path at WGPR

station-made recordings have already received compressing during the recording process. Ideally, they should not receive any more limiting but, since they must be processed along with tapes that need such treatment, the 3dB compression in this line at normal audio levels is accepted as a compromise.

By now the need for the many AGC systems in the WGPR audio chain should be obvious. The only practical way to provide the best audio from any of the station's input sources was to provide each with its own limiting systems adjusted to reflect the special needs of the equipment to which it is tied and to the program material it must handle.

As the diagram shows, the outputs of the six AGC units are adjusted to a level sufficient to drive the two program Telco lines. In the case of Studio A, this is +8dBm for each stereo channel. Since all other sources are mono, they must go through a splitting network in order to feed both lines. Loss in these networks is 6 dB, so output levels from the AGCs are set at +14 dBm to obtain the necessary +8dBm at the outputs of each splitter. These signals are then routed through the output switcher where the appropriate studio or dial switcher output is selected for broadcast. Controls for this switcher are located in both studios. The selected switcher output is then fed into the Telco lines and thus to the transmitter site some five miles from the studio.

At the transmitter, left and right channel audio is fed to a pair of CBS Volumax peak limiters. These units are

adjusted to give a minimum amount of limiting—just enough to prevent only the highest level peaks from overmodulating the transmitter. Of course, a higher compression level could have been used to gain a higher average modulation level. However, this would cause deterioration of the dynamic range at the high frequency end of the audio spectrum. This is caused by the action of the pre-emphasis network on the audio signal. The higher the input level to the Volumax, the more its built in pre-emphasis network will boost the HF range. The result is a higher level of HF, clipping when the signal is passed to the peak limiting section of the unit. It was felt that since a fair degree of audio processing had already taken place at the studio, any further processing at the transmitter, other than to prevent overmodulation, would be detrimental to the overall air sound.

Outputs of the Volumax units are fed to either of the station's two transmitters via the output routing switcher. This switcher function, plus all functions of both transmitters, are controlled by an ASI-designed automatic unit that senses main transmitter failure and switches all functions over to the auxiliary transmitter if the unit cannot return the main transmitter to the air. All of these functions are, of course, manually remote-controllable from the studio as well.

The result of our blend of automation and judicious use of AGC leveling devices is a smoothly running operation with optimum sound quality tailored to the station's diverse format and to its listeners' tastes. **BM/E**

Somewhere on this almost every kind of video

Assembled before you stands more video equipment than you'd ever need. But amidst all this equipment is that camera or monitor or VTR system you need to solve your own problem. Which is exactly why we make the world's largest line of video tape equipment.

So while some people offer a couple of monitors, and call that a choice, Panasonic offers you 14. Eight b/w CCTV studio monitors. Sold individually, coupled, or tripled. Plus 4 b/w VTR/CCTV monitors. And 2 color VTR monitors.

You also get a true choice in our choice of cameras. Four CCTV cameras. And 3 b/w studio cameras.

Our camera accessories include a sequential

switcher, 3 special effects generators, a sync generator, pulse distribution amplifier, and a video distributor.

For those who want a professional-quality color camera at an economical price, there's our color camera. Its accessories include a color special effects generator, color sync generator, and sub-carrier phase shifter.

If you're looking for an open-reel machine, you may not have to look further. Because we make 5 b/w VTR's. And 3 color. All 1/2" EIAJ standard.

And only Panasonic can give you a broad choice of magazine VCR's. Because we make a line of 1/2" EIAJ cartridge video recorders. Called Omnivision™. Plus a line of 3/4" cassette video



Age is the solution to problem you can think of.

orders. Called U-Vision™.
And if you need a security system, one of ours
probably fit your needs. We have two. One
simple. With mini-monitor, mini-camera. And mini-
price. Plus one sophisticated system. With time
base, that puts up to 48 hours of taping into 45
minutes of viewing.
We also have a 23-lb. portable camera and VTR
system. And for studio production, choose from 8
mini-studio systems.
Nothing's too small to escape us. We even make
different microphones. And sell video tape for
every one of our machines.
And believe it or not, everything we make isn't
the picture. But you get the picture. We've got

the answer to almost any video problem you've got.
To find it, just send us the coupon.

Panasonic Video Systems
Dept. BME-11 200 Park Ave., N.Y. 10017.

Please send me literature on: CCTV monitors;
 VTR/CCTV monitors; VTR color monitors;
 CCTV cameras; b/w studio cameras; color
camera; b/w VTR; color VTR; Omnivision™;
 U-Vision™; security systems; portable sys-
tem; mini-studio system; microphones.

Name _____ Title _____
Company _____
Address _____
City _____ State _____ Zip _____



Panasonic®
just slightly ahead of our time.

The TV Mobile Truck in Education—"A Window on the Classroom"

By David L. Bower and Frank A. Lester

Some practical examples in adapting college classrooms to television.

The project to construct a mobile TV taping truck to augment an existing on-campus closed-circuit system and to extend higher education to the general public began several years ago. Much could be written about the initial design and building, but it is the intent of this article to describe how The University of Tennessee utilized this truck to extend a segment of its various programs—"The Window on the Classroom"—to the people of our state. The cost of a custom-built vehicle was so prohibitive that we decided to fabricate our own truck using university facilities. The University Physical Plant Department agreed to construct the van in accordance with our general needs. The design and installation of all electronic equipment and related wiring were to be performed by the Department of Television Services.

Televising a live class on closed-circuit

Coverage of the different classrooms called for the development of several unique methods. In this first example (televising a freshman chemistry class live to students by closed-circuit), a very tight frame in scheduling clearly indicated rapid hookup and teardown. Also, the complexity of the distribution problems suggested some means of simplification of these connection and disconnection procedures. After considerable deliberation, we decided to construct a quick disconnect box for the truck which could be mated to the chemistry building by a special multiconductor camera cable, see Figs. 1 and 2. The cable provided the following: 1 multiple microphone feeds to the truck; 2 video and RF round robin monitoring to the TV classroom; 3 video and audio feeds to South Central Bell Telephone Company's distribution system; and 4 land line telephone facilities to the truck to permit communication with our distribution center on the far side of the campus.

The use of a single multiconductor cable for these many functions decreased the setup time appreciably and eliminated the possibility of hooking up lines in-

correctly. As it currently stands, it is possible to be ready for taping in fifteen minutes after the truck arrives at the chemistry building. The feasibility of using this arrangement for television teaching has proved to be a most practical means for covering classes on the Knoxville campus.

"The Chattanooga Connection"

The second example describes the method used in the taping of an entire college class as an event. An elementary economics class was selected on our campus at The University of Tennessee at Chattanooga. The taped series was designed to be broadcast later in the summer on all five of Tennessee's PBS stations.

It was our intention to preserve the image of the live class as much as possible. The instructor was encouraged to teach his class, as nearly as he possibly could, as if the equipment and crew were not in the room. It was, however, imperative that the tape be as good technically as we could make it. It was conspicuous then that some modifications be made without giving the class a reconstructed appearance.

The classroom selected (on the ground floor) was located a few feet from the place at which the truck would be parked. It was possible to snake the cables through a window. The AC power for the truck and the local telephone land line were connected to the mobile unit in a semi-permanent manner. In the classroom itself it was necessary to lower the high reflectance value of the front wall which would be, of course, visible to the cameras. A light shade of brown paint, compatible otherwise with the decor of the room, was selected; the wall reflectance level was lowered to suit our needs. The chalkboard frame, which was a highly-specularly reflectant chrome, was painted flat black.

The low ceiling height and small number of students in the classroom suggested that we give lighting techniques careful thought. We felt it imperative to keep all direct lighting off the instructor and his students. This we accomplished by locating two 1000-watt quartz fixtures halfway back in the room. Light was bounced off the white ceiling tiles to illuminate the teaching area.

Mr. Bower is chief engineer, and **Mr. Lester**, director of the Department of Television Services, at The University of Tennessee.

Two additional 500-watt quartz lights, with barndoors, were located in the front corners of the room to provide side lighting for the instructor. Another advantage of bouncing these two lights was that the resultant light was also much softer; harsh shadows were minimized. And the light was sufficient to take random camera shots of the students to allow for variety and punctuation in the lectures.

The instructor was provided with a small video monitor near the podium for cueing purposes. The student audio coverage was picked up by a floor stand AKG microphone equipped with a filter to minimize ambient room and street noise. The microphone level was boosted by a preamplifier before being fed to the truck so that a satisfactory level for students who wanted to respond to, or have dialogue with, the instructor could be sustained.

The three rear rows of chairs were removed from the room to afford maneuverability of the two cameras. A small title stand, independently lighted, was positioned at one end of this area for credits and supers. A test pattern and clapboard were located at the other end for production and engineering requirements.

As it turned out, the cameras (each of which was

equipped with a 25-250 mm zoom lens) were able to pick up the instructor and his chalkboard work quite well. Also, it was possible to intersperse the lectures with good side shots of the students, zoom in tight on their notes and, in most instances, read their written material surprisingly well!

We feel that we were successful in preserving the informality and intimacy of this small class (about 20 students) by prudent placement of the TV equipment and crew in the room, shown in Figs. 3 and 4. More than one student was heard to say, "... I soon forgot that the class was being televised."

"The Nashville Connection"—Complications

Taping a large class at The University of Tennessee at Nashville presented different problems. Unlike the situation at Chattanooga, the Nashville class convened for a three-hour period one night per week (the Chattanooga class met daily for considerably shorter periods). Attendance at the Nashville class (on introductory history) fluctuated erratically from one week to the next, even from hour to hour on a given evening. The room selected was of the amphitheater type and seated well over 100 people. Moreover, the classroom was located on the

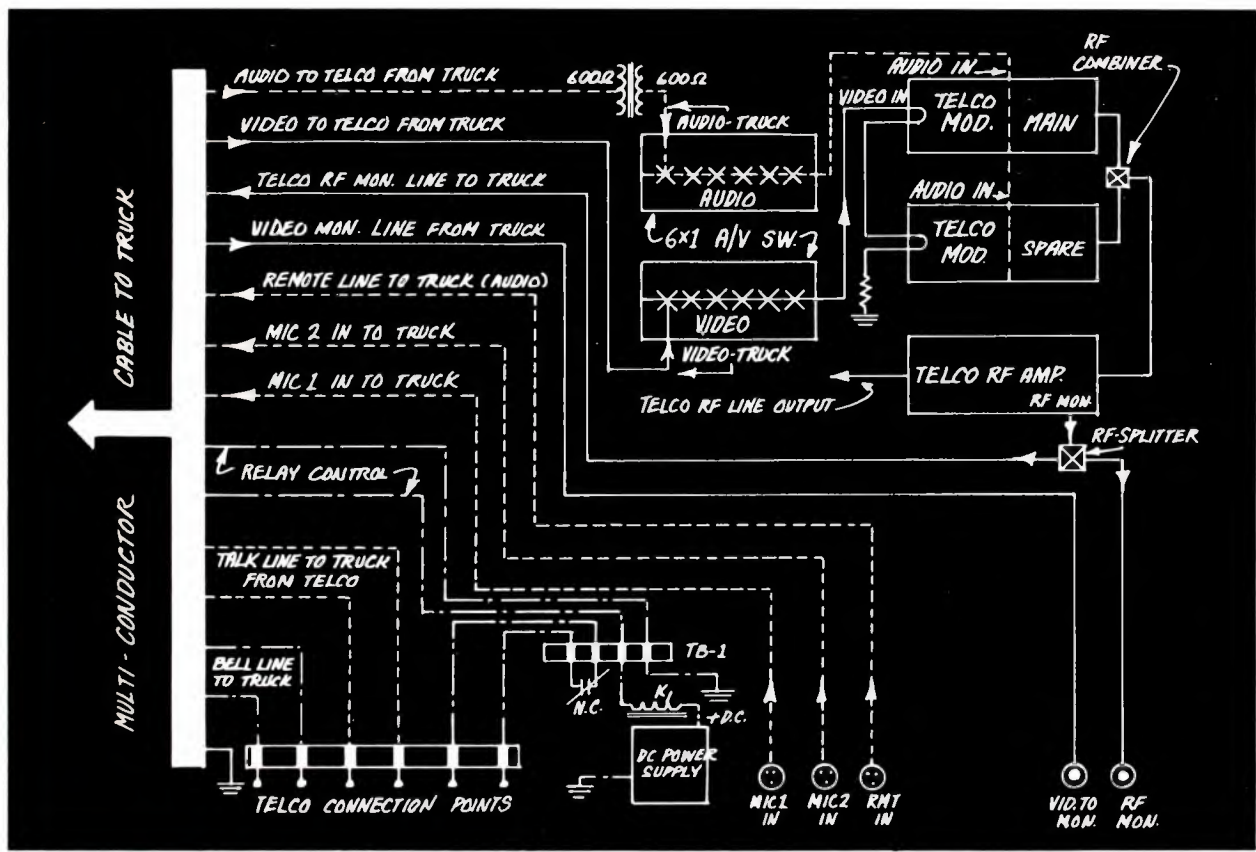

Fig. 1. Diagram of chemistry classroom designed for rapid hook-up and teardown.

Fig. 2. The multicongductor interconnection box for the chemistry remotes. Camera cable connects to the end of the box. Individual short cables feed between this box and the mobile truck connection panel.

opposite side of (and several stories above) the place where the truck was positioned. The cable distance was over 325 feet. Six men worked more than two hours knocking holes in floors and walls just to pull the cable to the classroom/auditorium.

Fortunately, the truck was parked and leveled in an ample loading dock area which could be totally enclosed at six o'clock every night. Thus, good security of the equipment could be maintained. Further, the vehicle was inside and protected from the weather, and our crew in the truck itself was isolated from the idle curious who often wander in from the street. There were minus factors in this location, however. Even though the truck was air-conditioned, inadequate ventilation of the loading dock area, when closed, caused some equipment overheating. We experienced, on an occasion or two, equipment malfunction or outright failure. This problem was rectified by the use of large air-circulating fans in the dock area until the onset of cooler fall weather.

The placement of cameras and ancillary equipment in the classroom posed another problem. Fig. 5. The seat-

ing area of the room was raked, and camera maneuverability was restricted. Trucking and dollying of the cameras were almost virtually out of the question, and we were often reduced to taping sessions of mostly zooming in, zooming out! We decided to place one camera at the very rear of the room for loose cover shots which usually included the backs of the heads of many of the students and occasional medium full-face shots of the instructor.

The other camera had to be placed in a restricted, small area near the front of the room at camera right (stage left) of the instructor who roamed freely across the breadth of a slightly elevated level. This camera was used for tight shots of the chalkboard, maps, and preponderantly profile shots of the professor. The camera was afforded some degree of movement between the first riser of the raked seating area and the front wall of the room. The camera could pan 90 degrees (and more) to the left for cover or individual audience (student) reaction shots. When this camera was in use, however, the television viewer was constantly mindful of looking

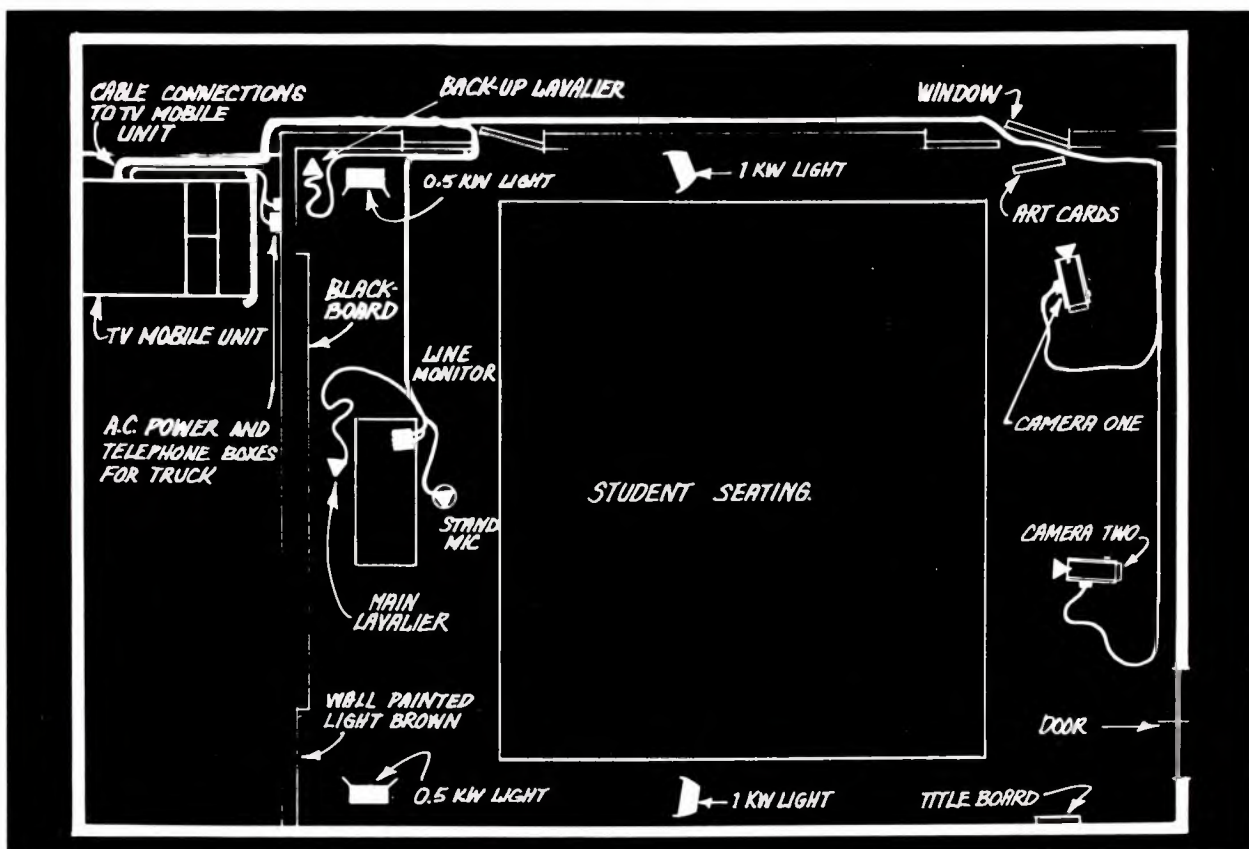

Fig. 3. Arrangement of the economics class at Chattanooga disrupts the class very little.

Fig. 4. The basic economics class at Chattanooga in progress. Photo courtesy Frank A. Lester



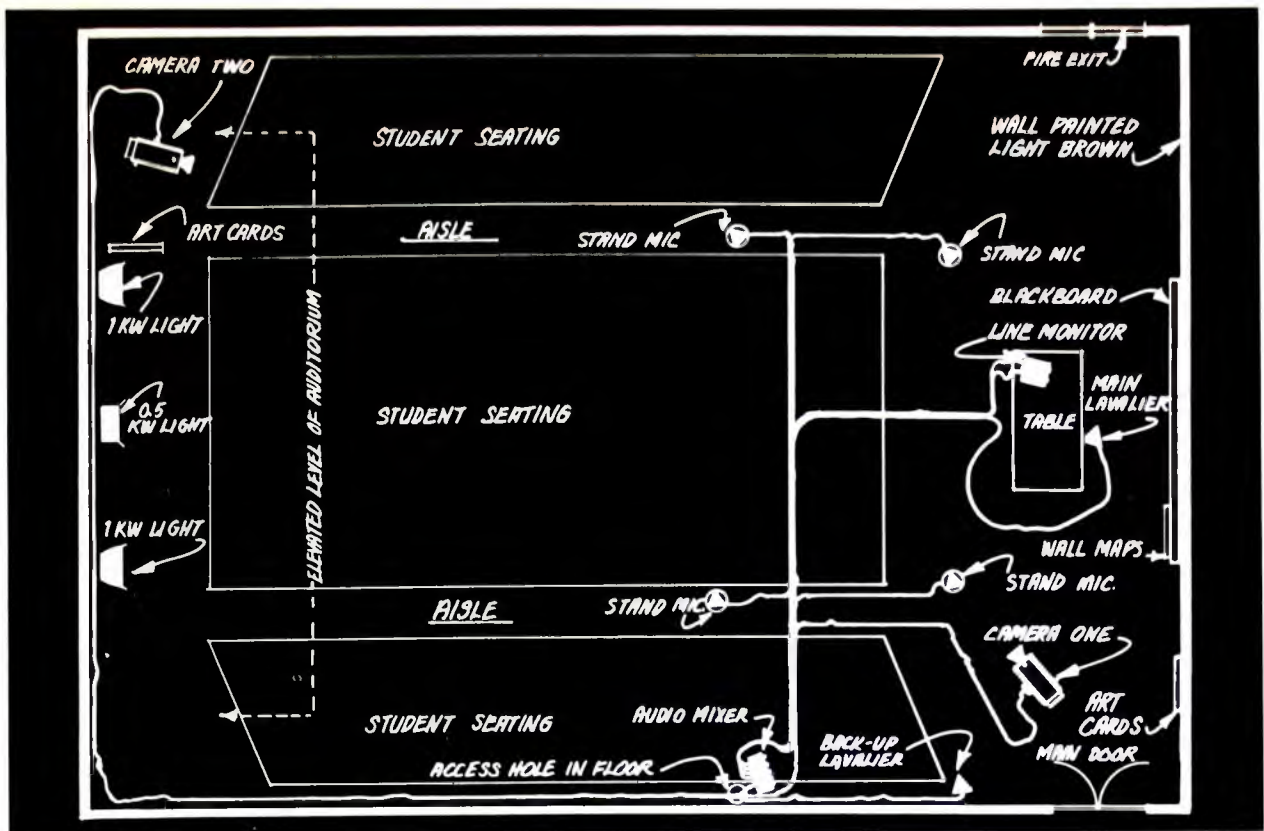

Fig. 5. Camera placement for this raked floor at Nashville was restricted.

Fig. 6. Camera in front of room can pan over 90 degrees covering instructor, blackboard, and some of the class. Photo courtesy Marshall Thurman

upward at everybody and everything!

The location of this front camera was not all bad. As can be noted in Fig. 5, some flexibility of movement in the aisle was possible. Without any lifting—almost an impossibility unless there are three or four sturdy crewmen available—or dismantling of the camera chain, the camera could be rolled out of the auditorium and stored in a utility room nearby. The rear camera was secured after each taping session and was not moved.

As with the Chattanooga remotes, it was possible to vary the taping routine by picking up shots of students taking notes. The front camera simply looked over the shoulders of students seated close to the camera. When this front camera was dollyed snugly against the front wall, the camera could look over the instructor's shoulder upward at the class. Because of the side location of the front camera, it could be kept easily out of the rear camera's view.

Title stands for credits and graphic materials were set up near both cameras to enhance flexibility of that aspect of production. The steep inclination of the audi-

torium's seating area allowed for the location of three lights at the rear to supplement the room's normal illumination. Here we used direct lighting because of the considerable distance between lights and subject. The height of the lights eliminated hot spot difficulties which are sometimes encountered when lights and subject are at the same level. Again, as in the Chattanooga experiment, the front wall was repainted a medium shade to decrease the contrast ratio problem created by a light wall. The chrome trim of the chalkboard, in this instance, was not repainted but covered with masking tape. This modification was not as satisfactory as painting the trim black, but it did minimize the glare problem.

All cabling from the truck was brought up through a hole in the floor and distributed to the various pieces of equipment. Because the room was heavily used for functions that were not televised, most of this cable had to be removed at the conclusion of each of our taping sessions. The cables were laced together and tagged so that the cable unit could be installed or removed

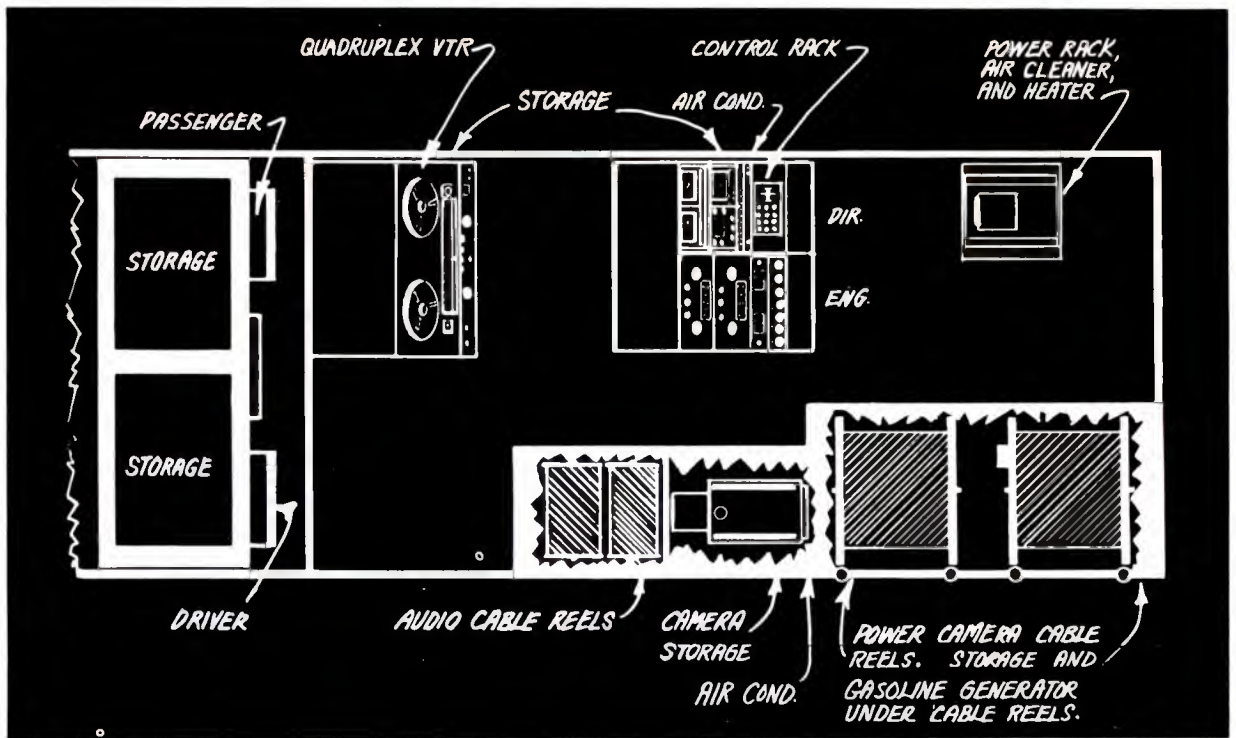

Fig. 7. Floor plan for mobile truck



Fig. 8. Outside shot of truck on levelling pad.



Fig. 9. Inside shot of truck showing location of equipment in rack. Photo courtesy Wm P. Wilson

quickly.

Four microphones on floor stands were placed, with the best strategy we could devise, among the students to cover their responses and questions to the instructor. These microphones fed a mixer in the room itself, and high-level audio was fed back to the truck. A lavalier microphone (and a backup) was provided for the instructor.

Interesting lessons—not all easily learned

We feel that the first example, the chemistry remotes, is representative of techniques which can be employed

to expedite setup and teardown for a remote in which time is critical. Also, such an arrangement reduces connection errors because multiple separate cables are eliminated. The second and third examples, in our opinion, represent methods and techniques for adapting the typical college classroom to television. We feel that careful and deliberate planning and staffing were responsible for these largely successful experiments—classes televised as events. It is true that some staging was an obvious imperative. To the television viewer, however, we contend that we achieved a depiction, in fact, of a real "window on the classroom."

BM/E

Select RCA film pick-up vidicons for your camera...

no matter who made it.

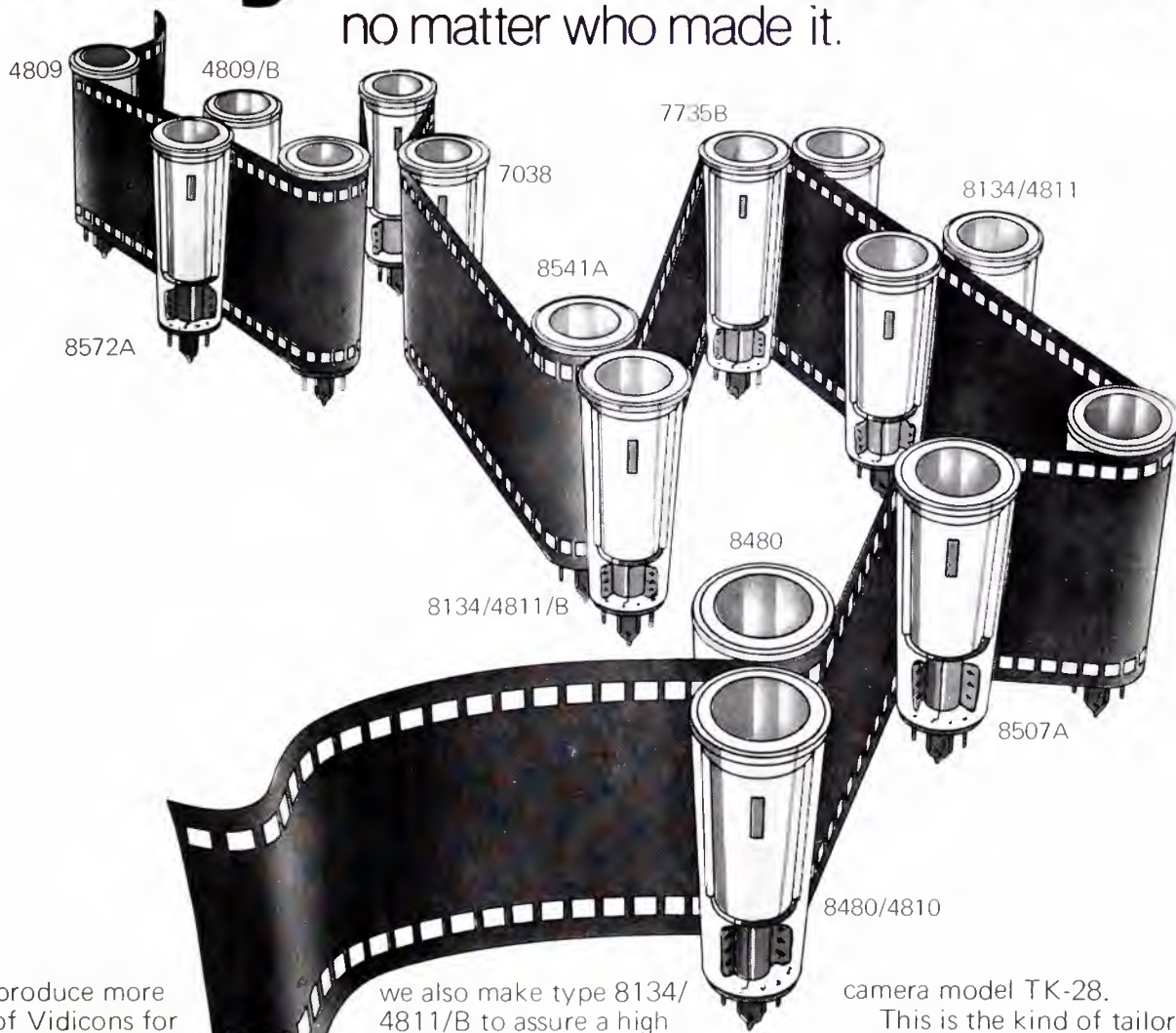

We produce more types of Vidicons for film pick-up than anybody else.

We make so many because we've learned that top film camera performance requires tailoring Vidicons to camera requirements. And our applications engineers have studied them all.

Take our 8480/4810 and 8134/4811 film pick-up Vidicons, for example. The specifications defining their performance characteristics are controlled to provide exceptional service in the RCA camera model TK-27. And

we also make type 8134/4811/B to assure a high blue-channel sensitivity for this camera.

Or consider our 4809 and 4809/B Vidicons. They're recommended because they are specifically designed, manufactured and tested to produce best performance under conditions imposed by today's 3-tube color film pick-up requirements. The 4809/B is specifically processed and tested to meet blue-channel sensitivity requirements. Both of these tubes have been successfully applied in the RCA

camera model TK-28.

This is the kind of tailor-made performance you can count on throughout the full RCA Vidicon line. Take advantage of it now. Just call your RCA Camera Tube Distributor or RCA Representative for complete information. Or write Commercial Engineering, RCA, Harrison, N.J. 07029 for your copy of the new RCA Camera Tube Product Guide (CAM-703B).

RCA Electro Optics

INTERNATIONAL SALES OFFICES: ARGENTINA—Casilla de Correo 4400 Buenos Aires/BRAZIL—Caixa Postal 8460, São Paulo/CANADA—21001 No. Service Rd. Ste. Anne de Bellevue 810 Québec/ENGLAND—Sundbury-on-Thames, Middlesex/HONG KONG—P.O. Box 112/MEXICO—Apartado 17-570 Mexico 17 D.F./SWITZERLAND—118 rue du Rhône CH1204, Geneva

Circle 128 on Reader Service Card

\$1890



If you're getting into or expanding production facilities you may need more flexibility than your broadcast board can give you. But full professional studio gear costs an arm and a leg, and you pay for a lot of things you may not really need.

You pay for what you need

up to four additional input modules and other optional accessories including talkback, remote transport control, quad panner, and headphone monitor.

That's why there's a TASCAM Model 10. It's an 8-in, 4-out mixing console, and it's just \$1890.

With the Model 10 you get what you have to have. Without sacrificing a single necessary function.

Each input module gives you mic and line attenuation, three bands of peak and dip equalization (two with frequency selection), pre- and post-echo send and receive circuitry, pan function, and a unique straight-line fader.

Each of the four submasters has a meter control switch (line/echo), independent monitor level control, echo receive level control, and a straight-line fader. You also get a master gain module and 4" VU meters with LED peak indicators. Plus pre-wired facilities for

That's what you need and that's what you pay for. Some things, however, you may or may not need, and we leave that choice up to you. For instance, the basic Model 10 is high impedance in and out, but studio line impedances are available optionally. You'll probably want low impedance mic inputs, but you may not need all low impedance line inputs. So we don't make you pay for them. You can order any combination of high and low input/output impedances according to your application.

Details and specs on the Model 10 are available for the asking. At the same time we'll tell you about our new Series 70 Recorder/reproducers.

We've got what you need.

 **TASCAM CORPORATION**

5440 McConnell Avenue
Los Angeles, California 90066

Circle 129 on Reader Service Card

High Schoolers Make Laws In Radio "Assembly"

In model legislature set up by station WKRS, Waukegan, Illinois, students as "House" and listeners as "Senate" debate and vote on some startling new "laws" for the state.

They voted for full majority rights for 18-year-olds, and overrode the "Governor's" veto of the bill. They set up state-supported re-cycling plants, made TV blackouts of local sports illegal, and introduced bills (defeated in the "Senate") for state aid to mass transit and no-fault divorce.

"They" were about 200 students from 15 high schools in the area around Waukegan, Illinois, who made up a

model "House of Representatives" in a series of programs organized by Station WKRS in Waukegan earlier this year. Developed in cooperation with the Lake County Bar Association, the programs stirred tremendous community response, particularly among parents of the students chosen by their schools to be members of the legislative body. As reported by Larry Leonard, director of public affairs for WKRS, the reaction of many parents echoed the statement: "This is the only thing that has turned on my kid since he started high school."

The students, in groups of about 30 representing various schools, acted as a bill-introducing body for "legislation" sponsored by the school bodies. They did not simply throw wild ideas into the legislative pot. Each bill was introduced with a lengthy, carefully-researched explanation, prepared in formal style. A surprisingly large body of knowledge—and political sophistication—had to be developed by the students in the course of getting their bills ready for voting.

Post-high-school listeners, connected to the studios by telephone, acted as the "Senate," introducing bills of their own as well as debating and voting on those introduced by the students. County Board Chairman Ron Coles acted as "Governor" and signed bills into "law," or vetoed them, as they came from the bicameral group.

In the course of the 30-hour broadcast, WKRS aired

continued on page 78

Amendments to the Motor Vehicle Code

An act to regulate the five areas of automobile standards: 1) auto safety; 2) car license; 3) engine limitations; 4) roadside standards; and 5) driver's license.

Be it enacted by the people of the State of Illinois, represented in the General Assembly, that these amendments be adjuncted to the Motor Vehicle Code

1) Auto safety check

An act to establish a regulatory check of all licensed automobiles in the State of Illinois

This bill states that all automobiles licensed in the State of Illinois must be checked for any hazardous defects every six months. If an automobile has some form of defect, it must be repaired and inspected at the owner's expense. After the automobile has passed inspection, a window sticker is issued to the owner of the automobile at the price of \$3.00. If, however, the automobile does not pass inspection, or if the owner refuses to make the necessary repairs, the sticker will not be issued and the owner's license will be suspended until the repairs are made. The check stations will be chosen by the state, but stations in the state can apply for this position by paying a fee to the state, approximately \$50.00. This Act will improve auto and highway conditions in the State of Illinois. Note: All new residents of the State of Illinois must have an auto check within the first month of their residence.

The profits made from the sale of the stickers and the fees from the check stations in the state should finance all necessary costs of this bill. This bill is effective as of January 1, 1974.

"Defects" for the purposes of this Act means anything having to do with the engine, signals, horn, lights, tires, anti-pollution, etc.

Any violation of this Act will mean suspension of the driver's license up to six months. If the violation should continue for a prolonged period of time, the owner's license will be ruled invalid and will be taken away until the proper repairs are made.

2) License plate renewal tags

An act to aid and simplify the present procedure of acquiring license plates. This state shall require license plates to be purchased every five years and renewal tags every year.

The tags shall be purchased annually at a price established by the Secretary of State.

It shall be required for each title holder to purchase a new set of the presently existing license plates every five years or when plates are so damaged as to be illegible as determined by the individual.



Lake County students acting as a House of Representatives. A bill is being debated over radio station WKRS. Station listeners, acting as Senate, also vote.

Is Instructional Technology More Than a Promise in Higher Education?

By Seymour N. Siegel

Comparing apples and oranges is traditionally the wrong thing to do in the American classroom. It might be equally frowned upon to compare farmers with university professors. But the introduction of technology into American higher education has been likened to the beginnings of the agricultural technological revolution. Robert Thomas, formerly vice chancellor for communications for the State University of New York, said some time ago, "The fundamental problem in both instances is the basically conservative constituency with which the innovators had to work . . . on the one hand self-employed farmers free to pursue their own ways without interference and deeply conservative and resistant to change; on the other hand, tenured faculty members relatively free to pursue their own ways, and again, conservative and resistant to change. Neither group was likely to embrace technology warmly, yet gradually over a period of time a technological revolution in agriculture did in fact take place. The fruits of that revolution have resulted in greatly improved products at lower production cost per unit."

Americans have always had confidence in the ability of technology to solve any problem even before a particular technological process had been invented. It would seem that with the availability of television, computers,

Mr. Siegel is Adjunct Professor and Director, Office of Educational Technology, City University of New York.

Modumath—A Remedial Program for CUNY-SUNY

Teaching remedial math is a major problem in higher education, especially with the rise of community colleges with open admission policies. Faculty doesn't really want to do the job. For this reason, however, the staff is favorably disposed to use prepared materials (of 22 CUNY-SUNY institutions, all expressed a willingness to try mediated instruction).

This fall these institutions will test a specially-designed video program, Modumath, designed to be self-instructing. Most schools will use the program in a video cassette form. The tapes are in color and well done, but straightforward. No frills are employed; simple animation is not "dated" and there is no identification with a particular ethnic group. The tapes are used with a study guide which includes objectives. A student can take a pretest to determine his level of entry. Script was prepared by Professor Miriam Hecht, who heads the remedial math program at Hunter College. A task force served as an advisory body. There are 40 titles altogether, covering whole numbers, fractions, decimals, percents, and integers.

Production was done with quad equipment. Animation is limited to that created by a special-effects generator. Color was simply added to black-and-white art electronically. A slide-audio cassette version was made by photographing the TV monitor. Sam Holman, producer, feels the cost was about one-half to one-third that of a film production.

film, and cassettes—to say nothing about the great strides in cable television—somewhere along the line the machine might be harnessed to assist in teaching and learning. The fact is, however, that all over America, educational technology with slight exceptions is being used minimally.

Almost two and a half decades ago, the educational community in the United States managed to achieve unanimity in the presentation of a case before the Federal Communications Commission for the reservation of television channels for education. The glowing promises of scholars and academics, of educational administrators, and school board chairmen, of politicians and government officials, as well as the practitioners of educational broadcasting, that the new technology would be the answer to many of education's problems were persuasive. The commercial broadcasting industry was caught off guard and more than 250 valuable channels were reserved for education. The performance by educational television stations throughout the United States, certainly in the field of higher education, has not met the promise. They have gone public. The euphemistic change in title from "educational television" to "public television" is more than that. It may well be that educators and non-commercial broadcasters "overspoke" themselves 20 odd years ago. Some hard-nosed reading of the testimony before the FCC might even allow the conclusion that this was one of the outstanding snow jobs ever achieved before that regulatory body.

In the context of the "go-go years" in the nation's financial community, it's interesting to note the high degree of correlation between the rates of support for public stations from school systems and the efforts to use the stations for instructional purposes. Back in 1966 the Ford Foundation's Fund for the Advancement of Education published a report which flatly stated that an educational station's income "from school programming is the most secure foundation of its solvency." In the intervening years there's been a sharp decline in the amount of support received from schools for television services. In New York State, for example in 1968-69, the educational stations averaged a little over 16% of their income from this source. In 1972-73, the estimated income has apparently dropped to 5% of the public stations' total income. This reluctance of schools to pay for television instructional facilities may have a serious impact on public stations' fiscal problems, but it is indicative of the overall decline in commitment to the promises made in the original petition for licenses years ago.

The onus for this failure to perform as promised should not perhaps be placed entirely on the technicians who operate public stations. The 1973 Report of the Legislative Commission on Expenditure Review of Edu-

ational Television in New York State devotes considerable space to an analysis of under-utilization: "... television was originally expected to be a prime instructional instrument replacing teachers and providing the central component for a complete instructional system. It was envisioned as a live, as well as taped, medium through which a professor could lecture with maximum coverage. A great deal of campus equipment and physical plant were designed and acquired under the influence of this "total teaching" concept but, after a period of time, this concept was abandoned.

Because there was a need for interaction between teacher and student, televised instruction on the campuses of the State University of New York is now used as a means of providing instruction for only part of a course. It's the general policy that no more than one-third of any three-credit course be taught by television. A great many programs are recorded on tape and seldom shown live. In other words, despite the considerable expenditure for equipment and hardware, television is used only as a supplement to traditional instruction. Because of the need for redesigning teaching methods which are necessary to accompany any major technological introduction, and since these have not been implemented in a manner conducive to achieving either an increase in productivity or a decrease in total costs, instructional television has "remained peripheral to instruction."

As in the City University of New York System, where the Chancellor's Committee on Educational Communications has recently reported an investment of more than five million dollars for hardware, and an almost equal annual expenditure for the maintenance and operation of that hardware, questions as to television's proper role in the State University System still remain. While instructional television serves many purposes "its real function on the campus has not been adequately defined to preclude its haphazard and wasteful use." Problems of campus acceptance and integration remain.

Some hopeful steps; obstacles to overcome

Considerable positive steps are being taken at CUNY. Negotiations for consortium-sharing of resource and possible co-production with SUNY and the California State System are far advanced and may have salubrious effects on high costs of acceptable software. Studies on the potentials of the cable and the formation of a community "educational user committee" are new constructive developments.

In evaluating the overall problem, however, it has been often stated that there's considerable indifference or outright antipathy toward using technology in higher education. The major objection by faculty seems to be based on reams of research which almost always suggests "no significant difference" in learning performance in the use of technology vis-a-vis conventional modes.

The few faculty members who have been "doing something with technology" have a deep-seated feeling that reliance on instruction of one's own design is pure virtue. There is almost an insurmountable feeling that most educational televised programs, for example, are poor programs, especially if done by somebody else. Most educators believe that television lessons, films, and computer programs are of poor quality, and do not meet individualized needs.

Problems of incompatibility and poor design in equip-

ment are being overcome, but slowly. This, of course, has haunted the audio-visual field in education almost from the beginning. To administrators, the rapidity of obsolescence which is characteristic of the communications revolution seems to be a cultural shock of overwhelming proportions.

The details of advanced planning in obtaining accessibility to both hardware and materials seem to be more than most faculty members care to cope with. Copyright problems always seem to lift their ugly heads, and the normal difficulties of the identification of cogent material are much more complex than merely flipping through a textbook.

With the normal lack of know-how and training in instructional technology, and the exclusion of media specialists from central planning, the greatest utilization of technology has been in the area of enrichment or enhancement, not in "stand-alone" instructional capability. (See box, Modumath.)

Despite the hundreds of millions of dollars which have been expended over the past two decades, on hardware and on materials, the penetration of new learning materials and media into higher education has been shallow. What many people feel is needed now is somewhat less financial support for the invention of equipment and more financial support for the development and utilization of what one already has.

It may seem an oversimplification to suggest that the capabilities of instructors would be expanded by the use of technology. To relieve them of the need to personally prepare and deliver elementary course segments, that change little from year to year, might normally be considered a welcome development. It would seem that time-saving methods would be provided which would permit the drilling of students in knowledge that must be mastered if the rest of the term's course content is to be fully understood. Certainly the capability for demonstration and illustration would be expanded. It would seem logical to believe that this would permit more time for preparation, as well as time for meeting with students and providing individual counseling and advice.

There is a pervading feeling that there is a lack of definitive administrative commitment to the use of technology throughout the educational establishment. This has to do with the reward system within higher education. Such goodies as tenure, promotion, and salary, go to the most productive in terms of research and writing, and not to those faculty members who are interested in improving the quality of instruction, or in reaching more students at lower costs. What seems most important at this juncture is the utilization of existing mediated courses prepared by someone else. Released time, salary improvements, and professional recognition would seem to be imperative. Any new reward system which might be devised, and which might provide faculty incentive for both participation and utilization, would be a plus in the introduction of technology.

Both the McMurrin Report, published four years ago, and the more recently published report by the Carnegie Commission on Higher Education, emphasized the fact that a college instructor purely as a purveyor of information is obsolete. His new role, not necessarily yet recognized by faculty, is the utilization of educational technology to make him a master of the resources of learning, with time and opportunity to cultivate students as

continued on page 80

Toward an Open Learning Society

By Wes Thomas

Many developments and movements are afoot, bringing us closer to the day of being able to acquire information and knowledge on an instant-demand basis—anywhere.

In Michigan, children are watching slow-scan television received by an FM radio. In Wisconsin, 2000 students throughout the state listen to a radio course and call in their questions and comments during the program. In Kentucky next year, high school dropouts will study for a GED by watching TV. And around the country imaginative experiments with interactive television, satellites, and other technologies are in progress. Open learning is catching on as educators are realizing what the post-TV generation has known all along: real learning can happen outside the classroom.

Meanwhile, educational television and radio are still poorly utilized in the classroom. Seymour Siegel, president of the Broadcasting Foundation of America, writing in this issue, offers these reasons:

- educational establishment conservatism;
- television often little more than the distribution of dull lectures;
- poor equipment design;
- inaccessibility of material and copyright problems;
- lack of faculty training in utilization of technology;
- media specialists not included in instructional design and planning.

In this article, we will discuss new techniques currently being used to correct some of these problems, including instruction outside of the classroom, interactive television and radio, video networks, consortia, and the "course team" approach. We will also explore where we are going—satellites, video cassettes, video discs, interactive home cable TV, etc.

Since administration and teacher apathy is so great, no frontal attack on the ineffective use of technology is possible. However, the Emergency School Aid Act, intended to reduce minority group isolation in elementary and secondary schools, offers one way to bring education into the communications age.

The U.S. Office of Education has awarded \$11.3 million for the development of programs in English-Spanish culture (Bicultural Children's Television), practical skills (WNVT), Spanish and English training (KLRN), ethnic-group promotion spot announcements (WTTW), and TV materials in mathematics (Educational Development Center).

These organizations seem to know how to make the media work. For example, in the mathematics series,

Mr. Thomas is president of Twenty-First Century Media Inc., a think-tank specializing in innovations in communications, and is coordinator of the Long Island Chapter of the World Future Society.

EDC plans to redesign both mathematics and television instructional techniques from scratch. According to Dr. Zacharias, project director, the series of 65 elementary school mathematics programs will avoid abstract approaches, such as set theory, and adapt a practical, concrete approach. Computer-animated films and materials for children to manipulate in the classroom will be used to make math a vivid experience, and EDC will attempt to involve some 200,000 teachers in the design and use of the series. In a refreshing emphasis on educating for the future, the use of pocket calculators (which is forecasted to be common by 1975, when the course will be ready) will be an integral part of the course.

Harold Wigren of the National Education Association, approaching the problem from the standpoint of the teacher, has pinpointed what's needed. Wigren recommends the following:

- design portable, lightweight, easy-to-use equipment for classroom use;
- develop teacher training in the use of technology;
- build in interaction in broadcast programming, rather than the present passive, one-way programming;
- develop equipment personalized for the learner;
- involve teachers in decision-making on the use of media;
- include teacher needs in the design of the system;*
- revise copyright laws to permit programs to be recorded off the air and used for a limited time before being erased so that broadcast materials can be fit into teachers' schedules.

A partial solution to the scheduling problem is the approach taken by the Long Beach Unified School District in California—programs are repeated up to 12 times a day on four-channel ITFS links to 77 schools. According to Dr. Harlan Levich, assistant director of Instructional Resources, teachers have been highly responsive to this flexible approach (a spinoff benefit is its use for communicating with the 5000 staff members, media preview, and teacher in-service training). System operation is enhanced by a semi-automated tape system.

The State of Virginia has developed another novel use of video cassettes. Faced with the "national radio quiet zone" in the western part of the state (due to a radio telescope observatory and the Naval Research Lab), the state has taken to bicycling video cassettes recorded off the air to the affected schools.

But perhaps the most encouraging development is that

*See "Preliminary Results from an Assessment of Teacher Needs," September 1972, available from the National Education Association.

educators are discovering that educational TV can be fun. According to Paul Barstow, supervisor of TV and Film Services, California's Torrence Unified School District conducts a popular weekly TV quiz program, "Brainstorm," for the district's 30,000 students, with a playoff at the end of the year. Teachers follow up by using the questions as springboards for class discussion.

Interactive Broadcasting—An Effective Learning Strategy

Educational broadcasting until recently has been basically an extension of the lecture—without even the chance to ask questions. Important efforts are now in progress to allow the student to participate in a two-way dialogue with an instructor. Some examples are:*

- The University of Southern California, under an NSF grant, is offering engineering courses over four ITFS channels to students in remote classrooms. The satellite classroom is equipped with a two-way audio system for communicating with USC instructors. An experimental program to award master's degree equivalency certificates is also being planned.

- Thomas Sheridan of MIT has conducted experiments with students watching a remote closed-circuit lecture. Students were able to feed back signals to indicate "too fast," "too slow," "don't understand," etc.

- The Metropolitan Regional Council Inc. recently conducted an innovative seminar on hurricane and flood disaster preparedness for county and municipal governments with participants at eight locations around the 1000-sq. mi. tri-state area of New York, New Jersey and Connecticut able to talk via two-way TV to the instructor or to other groups. The system, designed by the Rand Corp., uses the microwave band just below the ITFS channels, with main transmitter on top of the World Trade Center.

- The University of Wisconsin is running "closed-circuit radio"—an educational network in 176 cities in Wisconsin, with telephone feedback to permit as many as 2000 people to participate simultaneously in educational programs. Programming is carried on an FM SCA channel. Telephone tie-lines allow participation by resource people from other parts of the country. Eighteen different courses are available to the 20,000 participants in Wisconsin. A State Extension Network, using an "Electronic Blackboard" (a Victor Electrowriter), is also in operation by 20 stations with telephone voice feedback.

- Massachusetts General Hospital has extended its telediagnosis system, which uses full duplex video and audio to remotely diagnose patients, to educational applications. A course, "Counseling the Adolescent," is offered at several telecenters.

- The State Department of Education, Lansing, Mich., is pioneering in the use of slow-scan TV in education. Charles Ruffing, coordinator of Instructional Technological Services, has been broadcasting educational programs on an FM SCA channel to public schools in Flint, Mich. The system uses a 12KHz bandwidth for video and audio combined, with a 7-sec. video frame interval. An evaluation done by Michigan State University showed SSTV equal in learning effectiveness to regular TV for the same materials.

Ruffing, who says he was inspired by amateur radio experiments with SSTV, feels he is "working at the crystal-set phase." The system uses regular TV sets, with

*(For other examples, see *BM/E*, October 1972.)



Two-way instructional TV is being used at Independent School District 112, Chaska, Minnesota. System is owned by Community Information Systems located in the nearby new model city of Jonathon. Career education is facilitated by putting cameras simultaneously in both the classroom and the store or shop visited. Thus students can see and talk with a community or business leader at his place of work—and the "teacher" can see his audience. Interactive instructional programs of a simple sort can also be used. Pictured above is a matching game being played.

a scan converter at the school headend. Programs can be recorded off the air with a standard high-fidelity tape recorder. Scan rate can be controlled, leading Ruffing to call the system "controlled scan TV."

Other innovations by Ruffing include: an electro-writer network using an FM SCA channel; and a network of 15 institutions connected by two-way cable for school-to-school dialogue, with a random-access video cassette device at the headend, accessible by touch telephone.

- In Quebec, Selectovision, an experimental TV programming technique, was recently tried. It allows cable viewers to call in their preferences from a list of 80 titles of video tapes produced by citizens of the local communities.

- PLATO IV, being developed by the University of Illinois, is a computer-based system using a plasma display terminal with built-in random-access image projector and audio devices. The terminal is expected to cost the user 50-cents an hour including equipment, operating, and communications costs on a fully loaded system.

Using a novel communications technique to cut transmission costs, the system will be connected to 20 schools in the Champagne-Urbana area via an ITFS channel. The synchronous packing technique allows transmission for 1008 terminals over a single standard TV chan-

by laying down 1008 adjacent bits (one per student) on 12 horizontal scan lines (84 bits per line). This assures that a transmission error will have minimal impact on any given user. A phone line serves as the return channel for 256 terminals by using a polling technique.

At present, 61 sites in the U.S., Canada, and Europe are connected to the system—with a “hot line” to five sites in Moscow due for installation in November.

- A number of recent experiments on two-way cable TV will test interactive instructional TV. The most prominent example is Theta-Com of Los Angeles, Calif., which has developed the Subscriber Response System, permitting two-way instructional TV via cable. It is presently being tested in El Segundo, Calif., by TelePrompTer Corp.

TICCIT (Time-shared, Interactive, Computer-Controlled Information Television), developed by Mitre Corp., is another interactive instructional system capable of providing computer-aided instruction on a home TV set via cable, with telephone feedback to a computer. According to Tim Eller, group leader of the Interactive Television Project, Mitre is now looking for a city with two-way cable facilities and a representative demographic mix in which to experiment with community information utilities. Courseware presently being used includes junior college math and English.



Mitre's TICCIT system can use a Touchtone telephone to feed back information to a cable TV headend.

Potential Federal Sources of Funds for Broadcasting-Related Educational Technology Projects in FY' 74

Programs are under the direction of HEW's Office of Education, National Center for Educational Technology or the new National Institute of Education's Education & Technology Task Force. Guidelines are available from these offices. This list is not complete.

Call

- Adult Education/Special Projects, OE (NCET) (202) 963-7444
- Education Broadcasting Facilities, OE (NCET) (202) 755-7727
- Emergency School Aid/Educational Television, NIE (202) 755-7650
- Educational Research, NIE (202) 755-3507

Manufacturers working on subscriber response units capable of facilitating two-way instructional TV via cable include: Theta-Com and EIE, Los Angeles; Tocom, Irving, Texas; and Jerrold, Philadelphia. Others are known to be at work on the problem. A number of U.S. and Japanese manufacturers are developing “frame grabbing” storage devices so that several programs can be carried on a single channel.

Satellites Deliver Learning Everywhere

Arthur C. Clarke, the science fiction writer, at a UNESCO Space Communication meeting in 1969, remarked:

“A time is going to come when any student or scholar anywhere on earth will be able to tune in a course in any subject that interests him at any level of difficulty he desires. Thousands of educational programs will be broadcast simultaneously on different frequencies, so that any individual will be able to proceed at his own rate, and at his own convenience, through the subject of his choice.”

A giant step in realizing this forecast will be taken in April 1974, when NASA will launch the ATS-F satellite. ATS-F will beam ETV programming direct to low-cost receiving stations located in or near schools or community building in isolated regions of 23 states, including Alaska, the Rocky Mountains, and the Appalachian Region, where terrestrial TV coverage is not feasible. Funded by the U.S. Office of Education, the “Educational Technology Demonstration” will broadcast curricula in early-childhood education and career development.* The ATS-F will transmit two color TV signals, and will be able to send and receive telephone, telegraph, radio, TV, facsimile, and computer data. Two audio channels will permit students to select one of two languages. A two-way audio feedback via the ATS-3 or ATS-1 satellite will permit the student to interact with an instructor or other groups.

After a year of use, the satellite will be repositioned over India, where the Indian government will broadcast instruction aimed at curbing population growth and stimulating agriculture.

A new feature added to the system in 1973 is a local option in the Rocky Mountains to select (via satellite audio channel) materials from a published catalog. These materials will then be broadcast later in the day, with automatic recording at the local ground station.

Some experts are passing ATS-F off as a test of equipment rather than an educational innovation, since one year isn't enough time to prove whether the program is effective—and worth the cost. NIE's answer is that an experiment is the only way to determine the economics and audience acceptability of this new technology.

A predecessor to the ATS-F is the present use of the ATS-1 satellite for radio in-service training of teachers in Alaska by the National Education Association in conjunction with NEA-Alaska and the University of Alaska. The system links together teachers in 20 Alaskan villages and Bethesda, Md., in a two-way radio network.

The ATS-1 also serves to link schools and universities throughout the South Pacific and Hawaii. The “PFACE-SAT” broadcasts special lectures, is used for cultural exchange (school children in Alaska recently talked to

*The Rocky Mountains area has dropped early-childhood education.

counterparts in Hawaii), and substitutes communication transportation.

her in the future, the joint Canadian/NASA Communications Technology Satellite (CTS) will be launched in 1975. Among its user experiments will be an experiment in college curriculum-sharing between Stanford University and Carlton University engineering departments. According to Dale Lumb of the NASA Ames Research Center, full duplex compressed video TV with audio feedback will be broadcast via the CTS to permit pooling the resources of both schools. This approach should be particularly effective for what Stanford University's Edward Parker calls "communities of interest."

The next step toward Arthur C. Clarke's vision is to combine satellites with cable TV. Using the Canadian ANIK satellites and a transportable earth station (now on national tour), TelePrompTer is demonstrating a satellite-cable system, SpaceCast, which is a prototype for a national television network of the future. According to Robert Button, director, Satellite Operations, TelePrompTer Corp., economic analyses have shown that cable systems, interconnected by satellites, can be the most economical means of distributing educational materials.

With the FCC approval of several U.S. domsat plans in September, a national video network becomes a step closer. Although applications view data communications as the primary market, video figures prominently on three applications: Western Union, American Satellite Corp., and GTE/National Satellite Service (the latter a Hughes subsidiary).

American Satellite, a joint effort (Fairchild Industries, major, and Western Union International, minor), is showing very great interest in CATV systems and recently signed an agreement with microwave special common carrier, Western Telecommunications, the country's largest such carrier (13,000 route miles). WTCI will provide the terrestrial service which already serves many cable systems. Both WU and Amsat will be operative in 1974. By 1975, GTE/National will be ready. Since Hughes Aircraft is involved, and since Hughes has already planned an elaborate cable network in conjunction with TelePrompTer, a detailed proposal is likely to be forthcoming.

The cable industry is ready. The Cable Television Satellite Access Entity (CSAE), formed in late August, has 43 member firms (who have kicked in \$140,000), a nine-man executive committee and an able chairman, Rex Bradley of TeleCable.

Domsat plans reveal four to 15 receive/send earth stations being available, and 20 to 150 receive stations in the 1974-75 period. The number of transponders will grow from 12 in 1974 to 50 in 1975 and 200 by 1979. One transponder can handle one video channel or 1000 voice circuits.) Sat expert Beardsley Graham says it costs \$800,000 to \$1.5 million to maintain a transponder in orbit. This means a video channel reaching 50 states simultaneously could rent for \$1000/mo. For occasional use, rates of \$15-\$60/hr. are in the realm of possibility.

The principal problem will be one of interconnection. If the challenges are met, a national instructional education network will be possible. A good presentation of the possibilities are covered in Chapter 6 of NCTA's book, *The Uncommon Carrier*. Author is Daniel R. Vells, director of engineering and technical operations, BS.

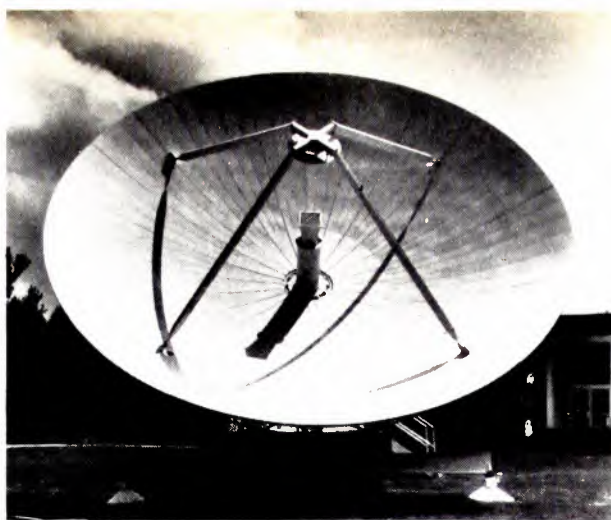

The satellite earth station antenna located on TelePrompTer's mobile station is a dish measuring 25 feet in diameter.

Private Uses of Video Growing

The *video network* is a relatively new term that describes what's going on. Use it loosely: Don't conjure up visions of ABC, CBS, NBC, PTV or even cable TV. If you have a half-dozen video players located in different spots and a class of programming that gets played regularly, you've got a video network going.

There are a host of experts ready to cooperate with video network planners: hardware manufacturers (video players, cassettes or discs), delivery boys (specialized common carriers), and software producers (in training, education, you name it).

A video network may be a string of public libraries equipped with video cassettes and some patrons with definable common interests. It can be doctors who need medical updates, or sailors at sea who need video diversion. It can be a chain of student unions or dorms on college campuses. It could be municipal governments exchanging info via TV channels over private microwave links. All of this became abundantly clear at the recent video expositions in New York City in September: Videxpo 73, sponsored by *Billboard*, and Video Expo IV, sponsored by *Knowledge Industry Reports*.

Videxpo 73 boasted some 300 exclusive reports on how groups are using video technology. Among those described: IBM's deployment of 650 U-matic machines in field offices and plants for marketing communications and training; Lincoln-Mercury's use of the U-matic in communicating with dealers; Hewlett-Packard's 1000-tape library covering descriptions of products, training tapes (H-P uses time-compression video to aid learning).

Videotape Networks, Inc. (115 East 62 St., New York City) is the name of one such network. VNI is an entertainment and information videotape programming service for more than 250 colleges with campus closed-circuit TV systems. A new medical network being formed will serve the 35,000 members of the American Academy of Family Physicians.

Development of low-cost program distribution via video cassette has caused a separate private television industry to emerge, said D/J Brush Associates at Video Expo IV. It has all come about in the last 18 months, has a compound annual growth rate of 30%, and involves a higher level of management than previous audio-visual systems. It's a whole new way of communicating within an organization, says Brush Associates.

Video Expo IV sessions did an excellent job of putting it all together in concise, up-to-the-minute reports on what's happening around the world in satellites, multipoint distribution systems, microwave, video cassettes and video discs.

You can be brought up to date by purchasing the conference report that will be available in a few weeks (write KIP, Tiffany Towers, White Plains, N.Y. 10602).

In September, in response to a White House request, Peter Goldmark, president of Goldmark Communications Corp., proposed "ENT/SAT," a domestic satellite system linked to cable TV networks and large-screen theaters to show cultural events in all 50 states for the Bicentennial. The system would be used for educational applications after the Bicentennial.

Open Learning—Making the World Your Classroom

At the Video Publishing IV conference in New York in September, Frank Norwood, executive secretary, Joint Council on Educational Telecommunications, Inc., presented the following as strong pressures on the educational system at this time:

- access to education by the disenfranchised millions;

Prescription For "Future Shock"

We can and must continue to make television work for us, and that is just what we are striving to do in South Carolina. We are doing it by offering 65 different courses on ETV to the public schools throughout the state, combining the talents of the finest teachers with the support of researchers, artists, and photographers. The same is true of the 18 courses for teacher in-service education. Through the ETV Network, any school in South Carolina can offer excellent resources on any subject.

For instance, industry has available continuing education (from basic literacy training and high school equivalency to supervisory and management development), and public service workers of all types receive training second to none. Our medical program has been in operation for nearly 10 years with training for doctors, nurses, dentists, pharmacists and others. In the planning stages is a project which will devote a special channel of our closed circuit network exclusively to medical education. ETV offers hope of increasing the number of physicians educated at greatly decreased cost. Paramedical personnel, dieticians, janitorial staff—the entire spectrum of health care personnel—can also be served.

In South Carolina, students throughout the state are attending ETV classes to study for their master's degrees in Business Administration. Engineering programs are extending the classroom to the student—wherever he may be within the state.

Other programs in South Carolina are reaching 100,000 adults with continuing education in their fields, through short-term courses designed specifically to upgrade their professional standing. Managers, technicians and supervisors in business and industry—members of all the major professions—citizens ranging from food service personnel to the men who write our insurance, from fork lift operators to the senior citizens who register us to vote, have all studied in short-term courses on ETV.

Our law enforcement officers who bring us to court, the attorneys who defend us, and the magistrates who try the cases, have all studied their parts on ETV. The man looking for a job and the manager who hires him have both been coached in their respective roles on ETV—as has the secretary who does all the paper work. And these are but a few examples of the innovative and unusual uses of ETV in South Carolina.

What does the future hold? Technically, we will further expand the closed circuit network; we will complete the open circuit coverage of the state with the construction of six new stations; experimentation with 2500 MHz will begin; we will study the possible use of satellite transmission, the use of video cassettes, TV recorders and so on.

The future does indeed hold a challenge to us—and to everyone remotely concerned with education. Fortunately, the future also holds the innovative tools with which to do the job. Our decisions must be bold enough to solve the problems we face and brave enough to solve them in time.

Henry J. Cauthen
ETV President

those excluded by entrance exams or tance from a school, or inability

icapped, housewives with childre.

• need for more relevant curric responsive to the interests and needs choice;

• necessity of expanding the time span of education to a life-long process.

Several efforts—part of the open learning movement—are now underway to achieve these goals. The pioneering British Open University, which offers university level courses to adults on public TV (*BM/E*, October 1972), and is probably the most impressive of these efforts, is now coming to America. Harper & Row is distributing British materials to three universities at this time. *The Open University*, Harper & Row catalog, lists 400 16mm-film titles, with 300 book and 200 audio titles as supplementary material. Rutgers University, for example, offers three courses on public television. Students can check out supplementary films, audio tapes, and paperback books at the media center, and can get help at study centers. Jessie Hartline, director of Rutgers' Open University Program, sees the efforts of most funding agencies limited to small research projects which produce reports that sit on a shelf. What is needed, she says, are a few well-funded projects on a mass scale to open up college education via TV to all, using the British integrated production team approach.

One such approach is S-U-N (State University of Nebraska) (*BM/E* October 1972), which is developing TV courses for adults under a \$500,000 O.E. grant. Projecting a budget of \$25 million for 20-25 courses, S-U-N is intended to become the first U.S. regional university. Samuel Gould, director of the Commission on Non-Traditional Studies* sees S-U-N as a model for the rest of the country. He also sees a need for consortia of institutions to share ideas and costs.

To that end, the Agency for Instructional Television, a joint U.S./Canadian effort, was formed in July. AIT, which incorporates National Instructional Television, will allow representatives of all state and provincial education and communication authorities to identify common needs and recommend projects for implementation by AIT. The first AIT effort will be a TV series on career education. A series of four regional meetings, beginning October 15, will establish priorities for AIT.

In a related move, the National Academy of Engineering, in a report to O.E., *To Realize the Promise*, May 1973, recommended a "National Corporation for Open Learning" to help states and regions develop a national network to achieve open learning.

The Office of Education is now taking open learning seriously enough to fund a study by the National Association of Educational Broadcasters, which will study open learning, including open admission and the open university, as well as a survey of existing projects, definitions of desirable characteristics, and recommendations. According to James Fellows, the study director, "We are still in the scribe phase of educational technology." He states that media operations for an open university (which might include 20,000 students), require a large-scale approach, different from the usual small ITV approach.

*Gould is author of *Diversity by Design*, Jossey-Bass, 1973 (available from McGraw-Hill), an important book on the open learning movement.

their co units
cation via
Fur tom,
municare
in la.S.
reb-

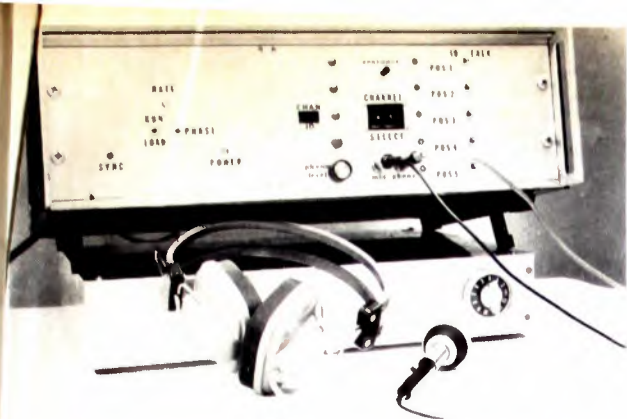

The "Audio 96" receiver above is part of a system developed by CablePlex, Inc. (New York City) that can transmit and receive up to 96 audio channels on one cable TV channel. A variety of audio tutorial instructional programs can be transmitted at once. Instructor can override the programming; the learner can signal the instructor if he wants help. Signals, incidentally, are in digital form and multiplexed.

ters around the U.S. and other parts of the world) by the Institute for the Future.

Alternatives to educational broadcasting are also evolving, with Portapaks used to create low-budget, informal programs and a delivery system consisting of videotape exchanges, such as the Union Resource Exchange Network (UNet), a national videotape-sharing system with over 20 producing affiliates, operated by the Union of Experimenting Colleges and Universities (Antioch College, Yellow Springs, Ohio).

For example, video collectives in Kentucky and Massachusetts are taping rapidly disappearing native skills, as well as boycotts and demonstrations the people can't see on commercial TV and the National Film Board of Canada's Challenge for Change project is putting Portapaks in the hands of low-income action groups to catalyze social change.

The main thrust of these invisible colleges is toward *current, meaningful problems*, such as the present strong interest in the energy crisis and the environment, which has generated dozens of informal networks, like the Pacific Northwest Environmental Communications Network, and the network associated with the *Alternative Sources of Energy* newsletter. While schools are still developing instructional materials on narrow "subjects" focused on the past, these networks are dealing with real-world, future-focused crisis problems about which education is largely oblivious.

Supporting these "underground" movements are technological developments which make alternatives to mass-oriented educational programming possible. These include Portapaks, "open access" cable TV, video cassettes, local cable networks, interactive broadcasting, and time-shared computer utilities. Rather than state-prescribed curricula with packaged, standardized subjects, many humanistic alternatives using such tools are possible. One scenario for the future paints a picture of a person in his/her home having, as Arthur Clarke envisioned, access to the world's information resources in low-cost computerized random-access data bases, with color TV display of text and video. Inspiring TV productions with the world's leading thinkers, curiosity, and the motivation of real-world problems would replace compulsory mass-oriented lessons. Access to satellites, broadcasting, and cable channels, equipment to locally produce audio and video materials, and people/resource

matching time-shared computers would provide the means required to establish "communities of interest" (as in the CTS satellite experiment) and to identify and communicate with facilitators, resource persons, and peers, as well as provide access to community information utilities. Children would have access to exciting exploratory learning environments like those described in *Education and Ecstasy* by George Leonard. The cost of such systems could probably be borne by re-channeling some of the billions of dollars spent annually, forcing people to learn irrelevant information.

As Toffler says in *Future Shock*, "Education must shift into future tense." BM/E

Universal Communication

All over the planet we are feverishly building more and more schools colleges universities. All along these schools are becoming superfluous.

A new *concept* of education is steadily replacing the school system. Where is this new concept of education practiced? Where can it be found?

It can be found everywhere. It is all around you. It is called Universal Communication—travel television transistor radios satellitephones videophones films microfilms cassettes computers international publications tele-sessions tele-newspapers communication satellites encounter groups dialogue travel . . .

This is the new education. It is the fastest educational movement in the world.

Today's youngsters are more knowledgeable than youngsters ever before precisely because of Universal Communication not because of schools.

Schools are actually holding them back thwarting their potential for more rapid growth.

Education has become too big for classrooms and schools. We have outgrown the school system.

Education like family is developing into a Process—unstructured spontaneous universal.

The whole planet is now a school.

From *Up-Wingers* by F.M. Esfandiary. © 1973 by John Day Co.

Carrier Current Radio Used in Housing Project

The tenants of Bromley Heath, a housing project under the Boston Housing Authority, have their own radio station WTMC. Using carrier current radio is an innovative step, towards improving communications in the public housing community.

Bromley-Heath, incidentally, is managed by the tenants themselves through the Bromley-Heath Tenant Management Corp. (950 Parker St., Jamaica Plain, Mass. 02130). This is the first public housing location where tenants manage and control everything within the boundaries where they live. The radio station helps management react to and serve a broad range of human needs in the community it serves.

Open Learning in Higher Education Conference

A National Conference on Open Learning in Higher Education has been called for January 16-18 on the campus of the University of Nebraska at Lincoln.

Focus will be on technology-based approaches to implement open learning. Write S-U-N, Nebraska Telecommunications Center, 1800 N. 33rd Street, Lincoln, NB. 58503.

**Some of our substitutes
for those big, fat incandescents.**



Networking Newsletter

SynergyAccess, a newsletter edited by the author, covers innovative and futuristic ideas in communications, media, networking, and technology for non-traditional education. Recent issues have listed learning exchanges and networks which are part of the "Invisible University" described in this article. *SynergyAccess* is published by Twenty-First Century Media Inc., 606 Fifth Ave., East Northport, N.Y. 11731.

Conference on Cable TV and the University

EDUCOM is planning a conference on "Cable Television and the University" in early 1974 in Dallas to stimulate use of cable TV in universities. A clearinghouse may grow out of this conference. Write: EDUCOM, Box 364, Princeton, N.J. 08540.

Charles Wedemeyer, Lighty Professor of Education, University of Wisconsin, sees the British Open University as "the most innovative university in western society in 1000 years." Wedemeyer is the author of the "Wisconsin Open School" proposal—a regional cradle-to-grave program for all citizens, consisting of an open school, uniform transferability of credit, a learning resources center, local community volunteers, and an integrated structure of program teams, delivery systems, and access systems.

The open school would deal with the problems of job retraining, dropouts, and inability to cope in a high-mobility society, by giving students compatibly accredited access to learning in any state in a region, at any age. He sees this concept evolving into a national delivery system, with learning combined with working.

At the Educational Media Council Seminar on Open Learning, Manpower Development and Training Programs in August, Wedemeyer stated these features of open education:

- opening education to more people;
- open admissions;
- open channels for communications via media (school without walls);
- open curriculum relevant to life;
- open access to learning outside of schools;
- open participation of part-time learners;
- open accreditation;
- open cooperation between institutions;
- learner-oriented;
- diminish the dependency of learners;
- create new roles for teachers.

In practice, programs advertised as "open" will possess some combination of these attributes. The following are some of the major innovative U.S. programs utilizing open learning via TV:

- Golden West College, Huntington Beach, Calif., (referred to as "Electronic U." in a *Saturday Review of Education*, May 1973 article), has pioneered in the use of individualized learning via audio and video cassettes, computer-aided instruction and ETV. The modern campus UHF station KOCE-TV, according to Vice President/General Manager Bill Furniss, offers "communiversity" courses to the local community, permitting 1300 students to study introductory psychology, consumer education, and history of art.

Golden West College President Dudley Boyce sees an

important role of the college in "lifelong learning for the entire population." He sees the college developing into an educational resource center, consisting of labs and a social center by the 1980s with greater opportunities for student individualized learning and flexibility. He emphasizes that the use of technology, rather than dehumanizing education, can free the instructor for more creative and personalized participation in the student's learning process.

- Kentucky Educational Television in Lexington is producing some 40 half-hour TV programs designed to help people get a high school equivalency (GED) diploma. The programs will be broadcast throughout the Appalachian Region starting in September 1974 (see box).

- Miami/Dade Community College is offering external courses (one on TV, one in radio) with "talk show" telephone call-in for questions and comments. Students fill in mark-sense cards for computer scoring, with "personalized letter" printouts on their progress. The series is also shown presently on 30 stations around the U.S. Plans call for adding courses from California Coast Community College District and others on an exchange basis. Courses are produced in a documentary-film format.



Library patrons can get instructional material via a videocassette recorder in a private carrel. Public Television Library has a program "Have You Watched a Book Today?"

High School Equivalency Certificate by TV—1974

The Kentucky GED series, which will be aired in September 1974, employs several innovative approaches to ETV. According to Ken Warren, project director, the "talking face" will be replaced by professional actors. The object will be to turn on learners with an entertaining format. The learner will be actively involved in each broadcast by completing practice exercises in a study guide and getting immediate feedback from the broadcast materials. In place of an organized class or learning center (as in the British Open U.), students will have access to "community contact volunteers" by a toll-free phone call. The series will be tested on adults studying for the GED, and will be promoted through a film, community publicity, and TV appearances and announcements.

A systematic approach has been taken—advisory group organized, content-research writers were put through a 40-hour instructional design workshop, objectives were determined, necessary skills and cognitive knowledge identified, instructional strategy selected, validation etc.

Five subject areas are included in the GED: social studies, literature, natural science, grammar and math. To cover content and to develop reading comprehension skills so essential to success, reading topics are drawn from the content areas.

- The University of Southern California has developed a public television humanities series, "Lights in the Abyss," funded by the National Endowment for the Humanities. A unique feature is that video cassette copies of the programs are taken to eight regional study centers, where the public can discuss the programs with USC professors at no cost.
- The PBS Public Television Library in Bloomington, Ind., has set up "WATCHABOOK" with video cassette players in libraries in Jackson, Miss., Norfolk, Va., and

Videocassettes in the School

Placing commercially-made films on videocassettes is being tried out by a school district in Utah. The Granite School District (Salt Lake City area) has signed agreements with several companies for such rights. Twenty-three pilot schools have been provided with videocassettes of hundreds of 30-minute 16mm films, and eventually the District hopes to have a video library in all of its schools. Reasons for Granite School District's action are that videocassettes are easier to handle, they can be revised and erased easily, and they can be more accessible to teachers.

The Virginia Public Telecommunications Council is also utilizing videocassettes in the public schools on an experimental basis. Bath and Highland counties, both located in the western part of Virginia, have difficulty receiving television signals, and no cable television is in sight for these sparsely populated areas. Thus, they cannot pick up instructional television programs from the nearest ETV station, WVPT-TV in Harrisonburg, Va.

In this experiment, videocassette machines are being placed in every school in both counties. The Council is making available all instructional television programs that are shown on WVPT-TV and cassettes will be manually delivered to the schools. Teachers have a calendar of programs and can choose what to use in the classroom as they so desire. This experiment's purpose is to ascertain just how videocassettes can be used to extend instruction. Cost of the year-long project is \$50,000.

For Further Reading

Toward a Learning Society and Priorities for Action, Carnegie Commission, October 1973 (available from McGraw-Hill).

Diversity by Design, S. Gould, Jossey-Bass, 1973 (available from McGraw-Hill).

AV Instruction: Technology, Media and Methods, Brown, Lewis and Harclerod, 4th ed., McGraw-Hill, 1973. Contains a chapter on the future of media and educational technology.

An Inquiry Into the Uses of Instructional Technology, Ford Foundation, 1973. Current and possible future uses of instructional technology, including a chapter on foreign developments.

Space and Education, NASA TT F-775, Belotserkovskiy, translated from Russian, available from National Technical Information Service, Springfield, Va. 22151 for \$3.00. Soviet domestic satellite and TV education in Russia.

Educational Media Yearbook, J. Brown, Bowker, 1973.

Teg's 1944, R. Theobald and J. Scott, Swallow Press, 1972.

Future Media AV Guide, January 1973.

Saturday Evening Review of Education, May 1973, special issue on educational technology.

Innovation in Telecommunications Technology: A Look Ahead, F. Korman, EDR, October 1972.

Educational Technology in Non-Traditional Studies, F. Norwood, Washington, D.C., Commission on Non-Traditional Studies, 1972.

On Learning and Social Change, Random House, 1972. See chapter on educational networking.

Learning Systems for the Future, Phi Delta Kappa, 1972; R. Barnes.

Deschooling Society, I. Illich, Harper & Row, 1970.

School is Dead, E. Reiner, Doubleday, 1972.

Bloomington, offering more than 100 half-hour units of public TV programs in videocassette format. Most popular so far: "Auto Mechanics," "Bill Cosby on Prejudice," and "Soaring over the Rockies."

Practically every college or university today has a study group, or at least an individual, planning university extension via new delivery systems. The aim is to provide personalized education tailored precisely for the individual. With the advent of reliable videocassette players, such as the field-proven U-matic type, and the presence of a telephone, the classroom is wherever there is power, a phone, and mail service.

The Invisible University

While there has been substantial progress toward open learning, critics such as Michael Marien, author of *Beyond the Carnegie Commission* (Syracuse University Research Corp., 1972), point out that the open education or the extended university concept is merely the extension of the same old fragmented, narrow, discipline-bound approach to the wider population. He sees a need for a new national movement toward truly radical change toward individual freedom for learners, such as in Campus Free College and the University Without Walls, where students are free to move in time and space and to define their own learning needs and goals in a problem-oriented manner.

While educational administrators are busily planning new multi-million-dollar programs, there exists another culture which is quietly functioning independently of the establishment. The "Invisible University," as Phil Werdell* describes it, "is a massive on-going educational process which surfaces publicly only for short periods of time . . . *The Whole Earth Catalog* was a major surfacing of a part of the Invisible University." Some of its other surfacings are seen in *Somewhere Else*, published by Swallow Press, which lists "places to learn directly rather than vicariously; places to learn to be a whole thing rather than to be a cog in a mass-production process." *Mother Earth* and *Radical Software* magazines; and *Big Rock Candy Mountain*, Delacorte Press.

It evolves informal networks (invisible colleges) for the exchange of information, with "information exchange" replacing "education." The "administration" of these invisible colleges is in the form of "learning exchanges" and resource-sharing networks.

Over 30 learning exchanges (inspired by Illich's *Deschooling Society*) are in existence in the U.S. at this time, with their purpose to match up people by common interests. There is even a learning exchange for learning exchanges, "Spectra-Center" in Michigan, which you can call free from anywhere in the U.S. (800-521-0410); and a computerized learning exchange, Resource One, in San Francisco, which lists local community resources.

The PLATO IV system (see above) combines the capability of computer-aided instruction with computer conferencing for direct dialogue between users around the country on any topic over a period of months, opening up a more humanistic approach to the use of computers in education. A similar system, "ORACLE," is in operation at Northwestern University, and computer conferencing is being developed for the ARPA net (a network of computers in universities and research cen-

*Until recently associate coordinator of the Master Plan, City University of New York.

Some of our substitutes for our substitutes.



Those big, fat incandescents blessed the world with a lot of big, fat fixtures and sockets.

So after we came up with our skinny, little tungsten-halogen lamps, the first thing we had to do was set them up on big, fat bases so that they'd fit the old sockets.

Which meant developing a complete line of Substitution Lamps. (You see some of them at the left.)

But soon new fixtures arrived on the

scene. These took full advantage of the inherent small size of Sylvania tungsten-halogen lamps.

(Which, by the way, outlast the fat incandescents about 3-to-1, don't blacken and lose brightness with age, and don't fall off in color temperature.)

For the new fixtures, we developed a complete new Standard Line of tungsten-halogen lamps, like the ones on the right.

Whenever studios replace their old fixtures with new ones, they can substitute

our new lamps for our Substitutes.

Which is OK with us.

Because both of these lines are so much better than the old lamps, that no matter which our customers use, we feel we've done them a world of good.

And there's just no substitute for that.

We have a brochure on each line. For your copies, write to: Sylvania Lighting Center, Danvers, Massachusetts 01923.

GTE SYLVANIA

**if we
told you
you could
cut your
tape costs
by at least
half, would
you buy
that?**



No, it's not a load of hot tape. Or seconds. You do it with our new, super slow speed Voice Logger Model 400. It'll rack up more than 600 hours of audio on one 7200 ft. reel of .5 mil triple play tape. And it'll do it, unattended, 24 hours a day for 12 days. (Or 24 days with one reel reversal.) That's about double the normal amount. And that's how you cut your tape dollars by more than half.

That's not the only feature. If a tape should break, a stand-by system can take over. At the same time, the transport control circuitry notes the failure and a memory logic system remembers (A) which pass giving track and direction and (B) record status. In case of power failure the memory will automatically re-start the logger in the last operating mode when power is restored.

Maintenance is simple, too. The whole deck pivots out. All electronics are in a slide drawer. And you can set up separate or simultaneous monitoring of up to 4 tracks.

The picture here shows a handy little accessory.

The Model 4400 Time Code Generator/Reader so you can encode time without dedicating an extra track. Quite a nice little package, right?

You can get all the specs (or a machine) by writing or phoning (415) 968-8389 TLX 345524 475 Ellis Street, Mountain View, California 94040



Circle 131 on Reader Service Card

Scully and OPTAC are registered trade marks of Dictaphone Corporation, Rye, New York

▶ Scully/Metrotech
Recording Divisions of Dictaphone

Focus on Tamaqua

By Mary Louise Hollowell

TV has permeated throughout Tamaqua to touch practically every department. Cable TV takes programs to the home.

Tucked away in the Appalachians in northeast Pennsylvania, Tamaqua is a town of 16,000, with a public high school enrollment of 1000. The town has a radio station, WZTA-FM, and two newspapers from nearby communities. Because of their location, the people depend on cable for any television programming. The closest local origination studio of the cable operator, Service Electric, is in Allentown, over 30 miles away—too far to be of great use to Tamaqua citizens.

But Tamaqua has local cable origination through its public school system, and mainly from the high school students. Videotapes are taken to a Service Electric headend at the edge of town and spliced onto the tapes run on Channel 2, the weather station. The school system can use this channel any time, so long as the cable company is notified. All equipment and production is provided by the school system.

Ms. Hollowell, in addition to writing in the field of broadband communications, has taught both in public school and at the college level. She is co-editor of *Basic Documents in Cable Television*, to be published by R.R. Bowker in 1974.

Service Electric wired the high school for closed-circuit video, and the school bought 17 TV sets. Many of these are located in partitioned classrooms, so that dividers can be opened and all pupils in the school can view the programming.

One example of all-school programming is the early morning show which began this fall and consists of school announcements, discussions of various school services, news of classroom and extra-curricular activities, and interviews. In the works is a plan to edit these daily shows into a 15-minute weekly show to be cablecast to the community.

Tamaqua Area High School began its cablecasting in the summer of 1972 with two subjects sports and music. A seminar on "lifetime sports" had coaches explain that program of golf, tennis, and swimming to the township. The music program focused on the school's summer music workshop and essentially acted as a recital for the participants.

Last year the high school became more active in video and by spring had produced many programs, including *Coaches' Corner* in which team captains and coaches were interviewed. This series, as well as coverage of



A student interviews the coach on the program "Coaches' Corner."



Coaches' Corner is a student-produced effort. Part of the floor crew is shown.

sports events, goes out to the whole community.

One popular program that, because of community requests, was cablecast to the town three times, was the coverage of the annual Bavarian Festival held in nearby Barnesville. Residents who had missed the program heard such enthusiastic comments from those who had seen it, that the former asked for it to be "rerun." Furthermore, a large group of people from Wisconsin who follow a particular polka band around the country asked to be included in the coverage. On the following day, they arrived at the school—several vans of them—to see themselves on the videotape!

The show *is* exciting. The videotape did not attempt to "document" the festival, but rather to capture the feeling of the event.

Tamaqua Area High School was able to initiate its video program because of an endowment from the Shepp Foundation. Ed Shepp was a coal baron in Tamaqua who established the endowment, which allows about \$12,000 interest on the principal to be given to the high school each year. Out of this, about \$5-6,000 must be spent on books and other library needs, and \$4-5,000 is earmarked for the senior class each year, for items of its choice which meet the criterion of being beneficial to all the students of Tamaqua. The class decides and then submits a proposal to the board of trustees. For two or three years, the project has been identified with TV.

For the 1972-73 school year, this \$4-5,000 was tied in with an ESEA Title III proposal (federal Office of Education—handled through the states), thus allowing Tamaqua to get a larger amount of matching funds from the

government for one of the school's many innovative programs—the Communications Arts Curriculum (CAC). Funding was granted in February 1972, and committees were formed and tasks assigned.

Fine arts and TV

The main thrust of the CAC program is an emphasis in the fine and practical arts, with a master-teacher, team teaching, independent study, and interdisciplinary program. Pupil participation will culminate with a creative performance. The project takes off on the assumption that the society (Tamaqua) places great importance on academic abilities and business, whereas artistic abilities are valued less, and at the bottom are the manual trades and service occupations. Through the CAC, the school system hopes to alter the value scale, so that the worth and importance of these latter, lesser valued areas will be understood and accepted. It provides an immensely creative outlet for the participants and also demands responsibility, self-discipline, and cooperation.

In addition to the programs already mentioned as having been done last year, the CAC beginnings also produced an interview with mayoral candidates. Because of community interest and requests, this program was cablecast three times also.

Drama, a likely subject for videotape, was included in Tamaqua's activities under the auspices of the CAC last year. Little evidence of interest or experience in drama had been evinced in the school or community before that time. In the school's courtyard, students performed *Man of La Mancha* to a live audience, and a videotape of the performance was cablecast over closed-circuit to the entire school. Also in the courtyard, pupils produced a Cabaret show, with checkered tableclothed tables, a bar providing fruit punch and cookies, the whole bit. This show was cablecast to the community, and also received so much response that the Cabaret was performed in the courtyard several nights.

George Miller, local newspaper reporter and former actor, was instrumental in producing these shows. He is a community resource person for the CAC, and is also helping in the efforts to procure nationally known people to participate in the "professional-in-residence" part of the project.

CAC funding allows for six professionals-in-residence for this school year: a poet, playwright, set designer, studio technician, choreographer, and artist, each to provide two weeks of their expertise, though not necessarily on consecutive days. Big names are among those being tossed around for consideration, and there is little reason to believe that these people won't be able to get them.

This year, Master-teacher for the Communications Arts Curriculum, George Taylor, has ten 12th grade pupils with him all day, except for English and history classes (because of other course requirements, only seniors are allowed to be full-time participants). Pupils in the program work out a "contract" with Taylor for specific projects they intend to accomplish during the year. Their work will be multi-media, and they will make great use of videotape.

Participating students enthusiastically told the author some of the concepts they are contemplating for their projects. One art-oriented pupil, Valerie Baranusky, may do an advertising project—developing a "product," packaging it, designing an advertising campaign, market

Multi-Use Planetarium

Tamaqua Area High School's Planetarium is another spot for multi-media instruction. Each class of Earth and Space Science regularly goes there once a week. Junior high and elementary classes also go there frequently for certain science lessons.

In addition to the traditional, expected uses of a planetarium, however, this one is used by other departments that find the overhead circular viewing a good way to present material. A reporter found two English teachers there, working out the kinks in a slide and audio presentation of a short story. Two or three slides would be flashed on the walls, one at a time, changing as the story went along. This presentation may be of value in units on the short story, creative writing, and developmental thinking, as well as others. It could possibly be relevant as far down as the fifth grade, and still be of use for 12th grade study.

The planetarium is also used for special shows, like the annual Christmas show for the community.

Public and Non-Public

Local non-public Marian High School hopes to get the same service from Service Electric cable company as does Tamaqua Area High School. Two staff members from Marian High School are represented in Tamaqua's Communications Arts Curriculum; and two students and one faculty member from Marian are members of the steering committee. They participated in last summer's workshop.

The school is instituting a few aspects of the CAC this year, and next summer will hold its own in-service workshop. Then, in the fall of 1974, Marian High School intends to initiate a full CAC program like that of the public school system, with which it has worked closely on video projects from the conceptual stages.



Camera control unit is "master control." Pictured here is the student director.



Cameras at Tamaqua are Panasonic. Their operation is easily mastered by students.

All photos courtesy Tamaqua student photographers.

esting it on the student body, and evaluating through a survey the success of her advertising.

Another CACer, Scott Davis, plans a series of videotapes on mining history of the area around the turn of the century. Besides doing book research, he will conduct field research and interview at least one old miner he knows, and probably others. He also intends to replicate the costumes of the era in creating an authentic portrayal of the people and the times.

As well as working on their own projects, full-time CACers, with part-time participants and members of the school's Media Club, will help in production of videotapes throughout the school system. Through workshops and committees related to the CAC and the projects done when Tamaqua first got its equipment, both teachers and students have participated in the development of

multi-media, non-traditional approaches to learning. The whole school is involved.

New ideas for 73-74

Among the new programming ideas for community cablecasting this year is a tape explaining the high school's new seminar approach to its American History course. Two teachers of the subject will, with students, prepare this program so that parents will understand the issue orientation that is replacing the traditional, chronological, textbook approach.

The school's Planetarium Director and Science Coordinator, Bob Fincham, is planning cablecasting of astronomy programs for the public. He hopes to attach a TV camera to the school's ten-inch cassegrain focus telescope, and roll it on its portable pier to the school

courtyard, to videotape the image of the moon and other large planets for inclusion in his program. He would possibly do this videotaping one night and include the tape in his "live" broadcast the next night, when he would talk about various configurations and tell his audience in what direction in the sky to look for certain things that evening.

Within the English Department, there is another opportunity for involvement with telecommunications media. The department has a mini-course approach, with more than 60 four-week offerings available for 10th through 12th grade pupils to choose among. This year, 40 of these courses are being offered, among them two broadcasting classes—an introduction, and an extension. In each of these, every class member is responsible for an individual or group project, using radio or TV, that is beneficial to the school or community.

But that's not all. Guidance counselor Nicholas Young also provides mini-courses of varied nature, offered to pupils during their study hall period. This year he is preparing a mini-course which will employ videotape in exploring occupations of the participants' choices. A student in this program would take the video rover out and interview people on the job—ascertaining qualifications, preparation, benefits, disadvantages, salaries, etc., and develop a file of materials on the occupation. The tape and other materials would be retained in the library for use by any interested student.

TV to extend to elementary and jr. highs

Presently most of the action revolves around the high school, but expansion is planned. The elementary and junior high schools do not yet have closed-circuit video—only one outlet each—but a new elementary school that would have the cable drop and cablecasting capabilities is envisioned.

Already, however, the elementary school has been involved in a videotape project, through a teachers' in-service reading program. In September, reading specialist Sandra Boltz, working with CACers and an administrative intern from Lehigh University, made videotapes to identify and demonstrate different aspects of the school system's Reading Criterion. The author watched videotaping that emphasized the following assumption: "All children do not enter school with the same experiential background: Thus, individualization of teaching approach of reading is essential from the first day of school."

This dry but important statement was well emphasized and the meaning made clear through interviews with first graders, who responded to questions like: Do your parents read to you at home? (often a response of "no"). What kind of books do you have? Do you use the public library? What are your favorite kinds of books? Do you watch TV? What's your favorite program? ("Batman" often was the answer.) Do you watch "Sesame Street?" "Mr. Rogers' Neighborhood?" Have you ever gone on a vacation or trip away from here? (One child had been to China; some had done little or no traveling away from the area.)

After the interview, each child was allowed to see himself briefly in playback—on "TV." Many children were taped and then a composite tape was made, using those parts that best developed the assumption quoted above, along with tapes exemplifying other aspects of the Reading Criterion.

Drawbacks to the CAC

School authorities had expected to have 30 participants in the CAC program this year. Instead they have ten.

Present drawbacks to the Communications Arts Curriculum (and possible solutions to them) seem to be: 1) Many prospective participants are tied into college preparatory courses and are afraid to miss any course. . . . The school is going to send a report of the program to various colleges that are often chosen by the student body to get the colleges' opinions of the program. 2) Again, showing concern for college and other school entrance, pupils have apprehensions of what they would have to do in the project—whether there would be a heavy work load that might affect their class standing. . . . Only seeing the program in action will answer this concern. 3) The selling campaign needs to be developed more. . . . Through all the part-time participants this year, the project is becoming more known, and through the many programs to be cablecast to the community this year, parents too will have the opportunity to judge for themselves the effects and accomplishments of CAC.

Later this school year, third graders will learn about various musical instruments, through videotapes of high school musicians playing their particular instruments and telling a little about them. At the end of the third grade, every child has the opportunity to pick a musical instrument for school instruction, which is provided from 4th through 12th grades. It is hoped that the tapes will aid the children in making their choices.

Hard work and enthusiasm puts it over

The many projects mentioned in this article can give you a sense of the activity going on in Tamaqua, but there are more for those of you interested in further information. And the man most responsible is Dr. Bruce Geiger, a well-known educator in Pennsylvania and outside the state too. He has had many achievements, but perhaps most demonstrative of his abilities in creating innovative, meaningful learning environments are his "outstanding teacher" awards. He has won four of them—three from the Eastern Pennsylvania Chemistry Industries Association, and one from the Pennsylvania Department of Education.

Geiger's enthusiasm and hard, responsible work have generated the changes in educational processes described here. But he sees the instituting of new, successful programs as depending on cooperation and interest from the whole system. Tamaqua's programs have the support of top school authorities and of teachers, as well as of students. Dr. Geiger had the author meet the Superintendent of Schools, Elbur Purnell, the high school's Principal and Director of the CAC, Curtis Steigerwalt; the President of the School Board, Fred Cox; and teachers and pupils too numerous to list here. All were busily involved in some aspect of Tamaqua's efforts to make education more pupil-oriented.

With all this backing, Tamaqua has a greater chance to really make its projects succeed than do school systems lacking in direction, commitment, willingness to change, cooperation, and involvement in every echelon of responsibility.

Because of size, if for no other reason, larger school systems would obviously have to make changes in order to transfer the kind of programming that Tamaqua Area High School has. Certainly, though, many of the ideas could be developed and used in different ways by other, and larger, systems.

BM/E

Filmchain Projection Simplified

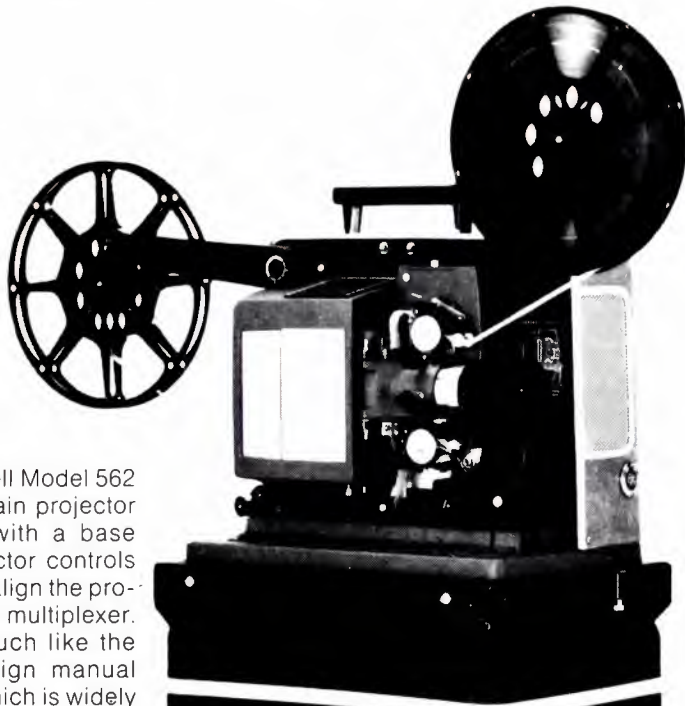

The new Bell & Howell Model 562 Optical/Magnetic Filmchain projector is delivered complete with a base which contains the projector controls and height adjustment to align the projector with TV camera or multiplexer. The projector is very much like the reliable 500 series design manual thread 16mm projector which is widely used in industry and education.

The Model 562 utilizes a synchronous motor, chain-driven film transport system including an automatic loop restorer to assist in projecting picture and sound into the camera for transmission over closed circuit or antenna-signal distribution. The pedestal includes facility for easily installing remote operation from a control panel.

Other Features You'll Like

Optical or magnetic sound playback. Choose from a wide variety of standard lamps and Bell & Howell lenses to obtain the optimum lumen output to the camera. A special torque release lever is provided when using reels with small hubs.

Other Important Details

Projector reel arms are gear driven, which provides quiet, reliable operation and constant take-up torque. The "Stellite," 3-tooth shuttle and ground and polished aperture plate, provides careful film handling in the projector transport system.

Self-lubricated bearings and other fine engineering details provide long life. The 500 series product design is well known to the hundreds of Bell & Howell service stations across the country, providing a ready facility to service any projector when maintenance or repair is required.

A Final Thought

The instruction books and service manuals provide the details necessary for installation, both electrical and mechanical, as well as remote control. Contact Bell & Howell, Chicago, for technical literature and the name of the local sources who will help you select the best combination of lens, lamp and equipment to project 16mm films for TV program distribution or local display.

AUDIO VISUAL PRODUCTS DIVISION
7100 McCormick Road, Chicago, Illinois 60645

 **BELL & HOWELL**

We simplify things. Life is complicated enough.

Circle 133 on Reader Service Card

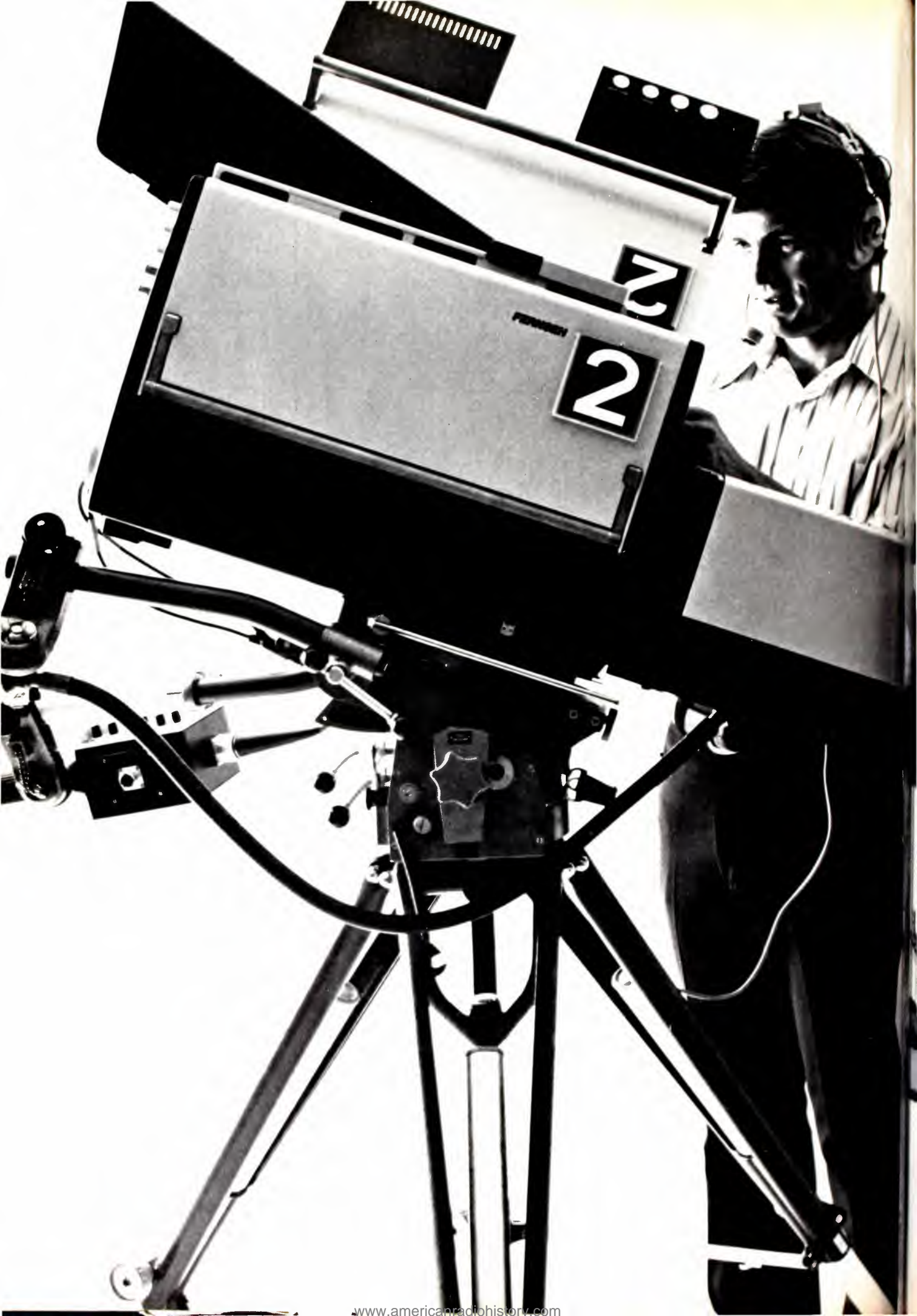

When we say interchangeability we mean interchangeability.

You can take one, or all, of the twenty modules and interchange them between cameras and maintain picture quality without additional adjustment, balancing, or fine tuning.

Our cameras were truly designed with interchangeability in mind.

You can take a module from one camera and put it in another camera. Or you can take a module from your parts stock and plug it in a camera. In fact, you can take a camera "shell" and put together a fully operative camera in about twenty minutes. The amount of time you save in adjustments and maintenance is remarkable.

Interchangeable modules are only a part of the Fernseh story. We have some other amazing features, too. For example, when you receive one of our cameras, it's ready for operation as soon as you unpack it. And, it'll perform to all specifications because each camera we make is pre-tested. We do something a little extra. We record actual performance characteristics for chromatic response and frequency response on each camera system.

There are a lot of things you should know about Fernseh cameras. Get detailed information by contacting your nearest Fernseh division representative at one of the offices listed below.

Chicago Headquarters

(312) 681-5000

Houston (713) 681-8461

Los Angeles (213) 649-4330

New York (516) 921-9000

Ramsey, N.J. (201) 825-1550

San Francisco (415) 583-9470

Circle 134 on Reader Service Card

**Robert Bosch
Corporation
Fernseh
Division**



the wings
of vision

BROADCAST EQUIPMENT SHOWCASE

For more than 20 years, Telemet has built precision products for the broadcast industry. Products designed for long life. To function with the ultimate of efficiency.

That's why each Telemet product undergoes extensive development and final field testing before it is available to the industry. The result: a long and growing list of satisfied customers.

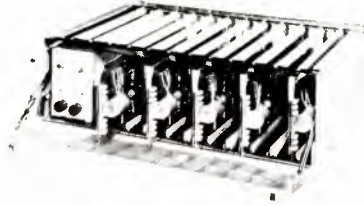

**Audio
DAs**



**VIT
Packages**

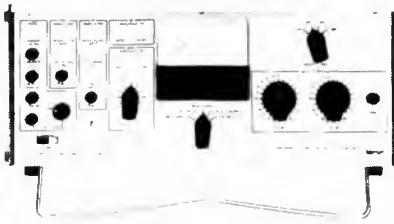

**Group Delay
Test Sets**

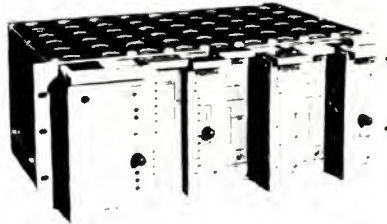

**Test
Sets**

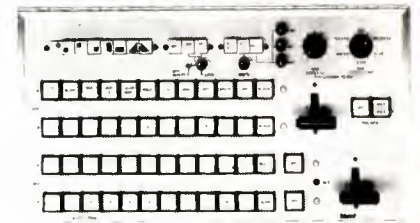

**Production
Switchers**



**Precision
Demodulators**



**Chroma
Keyers**

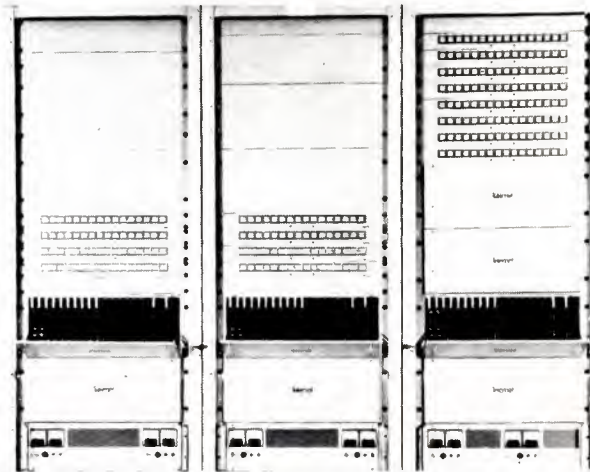

**Routing
Switchers**



better ideas for broadcasting
Telemet

A GEOTEL COMPANY

Amityville, New York 11701, (516) 541-3600

REGIONAL OFFICES

Atlanta, Ga (404) 939-7166 Chicago, Ill. (312) 627-6026 Houston, Tex. (713) 946-5796 Riverside, Calif. (714) 683-0641

Circle 135 on Reader Service Card

BROADCAST EQUIPMENT

Digital multimeter is self-powered, hand-held. Model 970A has solid-state numeric display right at point being measured, automatic range setting,



auto decimal and polarity indication, DC, AC, and ohms ranges. \$275. HEWLETT-PACKARD. 300

New intensifier silicon-intensifier target tubes for video cameras can operate at photo-electron noise limiting conditions, for extremely low light levels, or at high light levels with reduced photocathode voltage. Models 4849A and 4849 have reduced lag for low "hang-up," gain adjustment over a range of 8000/l. Model 4849A (higher blemish specification), \$3800; Model 4849, \$2750. RCA. 301

Two new crystal-controlled motors for Arri 35 camera have all electronics inside motor housing. Models CRA-6 and CRA-6A use oscillator accurate to 15 parts/million from 0 to 140 degrees F, have integral out-of-sync warning tone, fit standard tripod heads. CRA-6A (24 and 25 fps), \$1350; CRA-6 (24 fps), \$1250. CINEMA PRODUCTS. 302

Lens drives for viewfinder cameras

have cable-driven focus and zoom functions. Model V18-144MC (motorized iris for Vidicon tube cameras) and Model V18-144FMC (Dayonite auto filter iris control system) have slip-clutch protected gears, steel needle and roller thrust bearings. VICON INDUSTRIES. 303

Time announcer controller works from a 60 Hz digital counter, cycles any two audio sources between odd and even minutes. Model 781 has controls to stop counter for setting, indicator lights to show which audio source is coming up. Both one-shot logic ground-going start and relay closure are available. SYSTEMS MARKETING CORPORATION. 304

Phono record file has open bin at top for jackets, (capacity 320), lower sec-



tion for swing-out storage of records. Luxon Browser-File lower sections are numbered to correspond to jackets. JACK C. COFFEY CO. 305

VHF/UHF frequency counter operates from 5 Hz to 515 MHz with 50 mV sensitivity over whole range. Model 1980A has six-digit LED display, can be used with battery pack which is automatically charged during line use. \$795. JOHN FLUKE MFG. CO. 306

Antenna preamplifier for TV antennas is designed for Sitco single-bay anten-

na arrays. Model SBA-1 is an integral part of signal dipole, fits on pre-drilled holes on boom. \$54.60. SITCO. 307

Camera adaptor links lens of film projector to video camera lens, for transfer of color film or slide program to

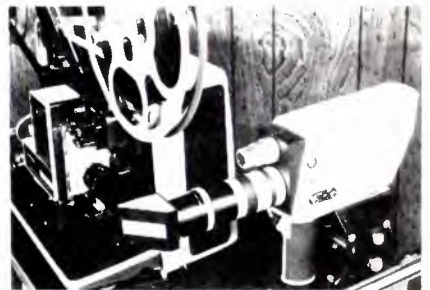

video form. Model VLC-8 interfaces with any film or slide medium and any video camera. \$199. AKAI AMERICA. 308

Video camera tube has full daylight to half moonlight capability. EMI Ebitron tube has trialkali cathode with extended red response, target with a gain of several hundred times from induced conductivity, EHT of 12 to 14 KV. EMITRONICS, GENCOM DIVISION. 309

Front-surface reflector device, using Mylar screen, allows positioning of field of view of fixed TV camera. Mo-



torized device can be remotely controlled, is usable in broadcast TV and CCTV, is especially valuable in viewing of surgical operations. RANK PRECISION INDUSTRIES. 310

continued on page 70

SPECIALIZED MULTIPLEX FOR THE BROADCAST INDUSTRY

- FM SUBCARRIER PROGRAM AUDIO DIPLEXERS.** The transparent program transmission for STL's, TV Networks and Satellite Links.
- SSB CHANNELS** for program audio transmission on CCITT Telephone Networks including L and N carrier.
- VOICE-OVER-VIDEO SUBCARRIER MULTIPLEX** For Microwave Applications including voice and data transmission combined with video for Remote Control, ETV Talk-Back and Inter-City Communications.

For Cable Applications including voice and data transmission channels for Industrial Complexes, Hospitals, Campuses and Local Government Communications Networks.
- COMMUNICATIONS SYSTEM BUILDING BLOCKS** including Video and Audio Filters.

Write or call today for full details and prices.

Telephone: 415/825-7500

Coastcom

2346 Stanwell Drive
Concord, Calif. 94520



NEW PRODUCTS

One-station FM receiver uses crystal-controlled oscillator. XTL-FM has frequency accuracy of .01% air suspension speaker, 4 microvolt sensitivity for 30 dB quieting, less than 1% distortion at 75 KHz deviation. **FIXTURE ELECTRONICS, INC.** 311

Heat-shrink tubing has blue stripe that turns brown when enough heat has been applied. Raychem Cable Sleeves have low heat requirement, can be removed and replaced without damage to cable. **ANIXTER-PRUZAN.** 312

Sound-level test sets each includes a sound-level meter, acoustical calibrator, carrying case. Series 370 and 375 sound-level kits are self-contained with battery pack, have single-frequency or multi-frequency calibrator, foam wind screen, "A," "B," and "C" response, instruction manual. \$397 to \$587. **TRIPLETT CORPORATION.** 313

Battery-operated wall clock has accuracy of one minute a year, less than two-tenths second a day. Westlock Quartzmatic runs on two "C" cells (life about one year), is highly immune to battery power fluctuation. **GENERAL TIME SERVICE.** 314

Dual active program equalizer has two independent units in one rack mount. Model PEQ-82 has unity gain in each



unit, maximum output of +24 dBm, controls continuously variable from -12 dB to +12 dB at each of four frequencies simultaneously; Hi and Lo filters are also included. \$325. **AUDI-TRONICS INC.** 319

RFI analyzer covers range from 10 KHz to 250 KHz with sensitivity of 0.014 microvolt. Model NM-12AT was formerly made under Stoddart brand, is line or battery operated, has an internal spectrally-flat impulse generator, reads average, quasi-peak, and peak field intensities. \$4860. **SINGER INSTRUMENTATION.** 315

High-voltage cable splice kit supplies all components (except standard hand tools) for permanent, hermetically sealed splices in cables carrying up to 15 kilovolts. Hi-VoltZ requires no heat or flame, takes about 20 minutes for a splice in shielded cable. **ZIPPER-TUBING CO.** 316



Stanton. Benchmark for an Industry.

Stanton's 681 Series is the Calibration Standard to recording engineers such as Robert Ludwig.

Whatever the requirements for recording and playback, Stanton's Series 681 cartridges are the Calibration Standard. And there is a 681 model engineered specifically for each of these critical applications. That's why Stanton is truly the Benchmark for the industry.

The Stanton 681A—For Cutting Head Calibration. With Stanton's Model 681A, cutting heads can be accurately calibrated with the cartridge, for it has been primarily designed as a calibration standard in recording system checkouts. Frequency response is factory calibrated to the most rigid tolerances and the flattest possible response is assured for precise alignment of recording channels.

The Stanton 681EE—for Critical Listening. Stanton's Model 681EE is designed for low-distortion tracking with minimum stylus force, regardless of the recorded velocity or the distance of the groove from the disc center. High compliance, low mass and low pressure assure perfect safety even on irreplaceable records.

All Stanton Calibration Standard cartridges are guaranteed to meet the specifications with exacting limits. Their warranty comes packed with each unit—the calibration test results for that individual cartridge.

For complete information and specifications write Stanton Magnetics, Inc., Terminal Drive, Plainville, L.I., New York 11803.

All Stanton cartridges are designed for use with all two- and four-channel matrix derived compatible systems.



NEW PRODUCTS

Fiber-optic face plate version of 8541A Vidicon camera tube is one-inch diameter, magnetic deflection tube. Model 4569 is electrically and mechanically interchangeable with Model 8541A, can be coupled to fiber optic pipes for around-the-corner viewing, or other fiber optic devices such as image intensifiers or electronic shutters. \$400. RCA. 317

Audio-effects device will add reverb to broadcast or spot-production audio. The Resonator also has a low-cut filter for simulating telephone quality. \$315. DYMA ENGINEERING. 318

Vector output module can be connected to color television monitor of 5000 series. In conjunction with an x-y oscilloscope, it will show chrominance vector relationship. \$90. CONRAC CORPORATION. 320

Cartridge playback and recording units have solenoid controls and plug-electronics. Logi-Carts have vernier azimuth and parallelism adjustments, regulated power supplies, provision for remote control. SYSTEMS MARKETING CORP. 323

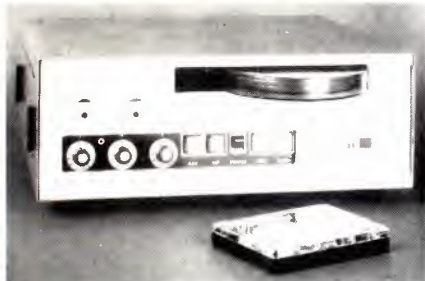

Digital timer is capable of accuracies to one microsecond, has BCD output, flexible display. Series M timer uses 60 Hz supply or optional crystal oscillator for time base, can time sports events, in-hospital intensive care, commercials for radio and TV, or laboratory applications. It will drive computer peripherals such as digital printers. \$175 and up. THIEM INDUSTRIES. 321

Digital weather station shows wind speed and direction, temperature, and other weather facts on digital readouts. EDS-9000 Series offers various combinations of weather readouts, with illuminated digital display viewable on TV or cable cameras, as well as usable for any weather monitoring application. F & P SYSTEMS. 322

Magnetic tape tension gage measures static and dynamic tension of tapes

continued on page 72

"I wouldn't be without it!" —

Jack McCoy, Program Director at KCBO Radio in San Diego uses his Multisync. Multisync gives continuously variable speed control of tape decks and turntables.

- Save that "61 second" spot.
- Balance "off speed" tapes.
- Sharpen your sound!

Ask the people who know—the people who use Multisync:

KCBO/San Diego, Calif. • WKTO/Pittsburgh, Penn. • KRQQ/L.A., Calif. • WMYQ/Miami, Fla. • WOKY/Milwaukee, Wisc. • KSLQ/St. Louis, Mo. • KOIL/Omaha, Nebraska • KBEY/Kansas City, Kansas • KHJ/L.A., Calif. • WDRQ/Detroit, Mich. • WLQY/Fort Lauderdale, Fla. • Fanfare Recording/El Cajon, Calif. • Studio West/San Diego, Calif. • Caribou Ranch/Nederland, Col. • Dijobe Sound Recorders/Orange County, Calif. • Lee Furr Studio/Tucson, Ariz. • Studio East/Milwaukee, Wisc. • 24-16 Corp./Mexico City • Erwin Wasy Adv./L.A., Calif. • Emmitt Rhodes/Hawthorne, Calif. • Atlantic Records/N.Y. • Fred Arthur Productions/Denver, Col. • Las Vegas Recording Studio/Las Vegas, Nev.

Then call us, or write for further information: Pacific Recorders, the total equipment suppliers!

PACIFIC RECORDERS AND ENGINEERING CORPORATION
11760 SORRENTO VALLEY ROAD, SAN DIEGO, CALIFORNIA 92121
TELEPHONE (714) 453-3255 TELEX 695008

Circle 138 on Reader Service Card



TOPS!

That's LPB's stereo S-13B console, our top-line audio control center. Features include:

- 18 stereo and 6 mono inputs.
- Step attenuator mixers.
- Telephone-type switches.
- Plug-in fiberglass circuits.
- Stereo 12 watt/channel monitor.
- Internal cue amp and speaker.
- All transformer input and output.

The features and quality of LPB's S-13B just can't be found in other consoles at comparable prices. Take a hard look at the S-13B before you make a mistake!

LPB has a complete line of mono consoles, too, and everything that goes with them. Call or write today for complete information.



LPB Inc.
520 Lincoln Highway, Frazer, Pa. 19355
(215) 644-1123

Circle 139 on Reader Service Card

NEW PRODUCTS

from 1/8 in. to 2 in. widths. Tenteleometer is hand-held, shows tension at heads or reels, helps trace servowander, head and clutch wear, belt slippage, transient or intermittent tensions. TENTELE. 324

Sound level meter is portable, has "C" weighting. Model 451C is pocket sized, covers range 45 to 130 dBc, runs on a single battery that gives about 200 hours of operation. \$98. SCOTT INSTRUMENT LABORATORIES. 325

FM frequency and modulation monitor has superhet front end, eliminating need for RF amplifier in remote applications. Model 723 gives digital display of frequency error, with 1 ppm/year accuracy, using crystal oscillator time



base in oven. Peak-reading modulation meter is supplemented by peak flash-

ers, positive and negative, individually settable for flash point. Pushbutton converts instrument to 6-digit, 10 MHz frequency counter. TIME AND FREQUENCY TECHNOLOGY, INC. 326

Three-digit multimeter has four ranges of AC and DC voltage, 5 ranges of AC and DC current, and 6 resistance



ranges. Model 3/24 weighs two pounds with battery (300 hour life), has various options for extending voltage and frequency coverage. \$195. BAL-LANTINE LABORATORIES. 328

Multi-frequency repeater tone panel will handle up to 18 separate functions, with a plug-in card for each. Model RCP-780 can supply many tone system configurations: audible or sub-audible tones, pulses, in different encode and decode combinations, for

community repeater systems or wherever tone control of many functions is required. ALPHA ELECTRONIC SERVICES INC. 330

Broad-band interchangeable cable taps have 2, 4, or 8 outlets. Series IBB come in 11 different tap values, can be interchanged without disconnecting cables, have a common top plate. JEROLD ELECTRONICS CORP. 331

Linear audio controls have conductive plastic for guaranteed minimum of 100,000 operations. LM4-200/LM6-200 Series have 600 or 10,000 ohms impedance, linear, audio, or logarithmic taper, attenuation of 85 dB, optional cue switches and detents. WATERS MFG. CO. 327

Video color camera for CCTV has three plumbicons for low-light-level self-contained operations. Model CTC-3XP has 5-in. viewfinder monitor, auto iris control, remote control option, built-in EIA sync generator and color encoder, six color correction filters, can use interchangeable lenses including zoom. GBC CLOSED CIRCUIT TV CORP. 333

Level measuring set covers 200 Hz to 2 MHz, includes a tuning unit, receiver, and generator in separate units for various test combinations. Model



NEW from cinema products



AERO-KIT The All Focusing Quartz Location Lighting Kit

The compact **Aero-Kit**, which weighs less than 31 lbs., includes: two *focusing* spot lights with two detachable rotating four-way barndoors; one *focusing* fill light with integral four-way barndoors; two scrims; three 10 ft. long three-wire cables (with in-line switches); three 15 ft. long three-wire extension cables; one gator grip; three professional-type stainless steel light stands; and a sturdy aluminum carrying case, measuring only 6 1/2" x 12" x 26 1/2".

The light stands (10 ft. high when fully extended, and 24" high when telescoped) are specially designed with adjustable legs which permit easy and stable placement of the light stands on uneven ground surfaces.

The two *focusing* spots and *focusing* fill light (equipped with new and improved quartz lamp sockets which are extremely heat resistant) operate at 120-volts AC/DC with 600-watt lamps, and can also be used with 250-watt lamps for 30-volt battery operation.



The **Aero-Kit** ... ideal for on-location filming and still photography.

cinema E products
CORPORATION

Technology in the Service of Creativity
2044 Cotner Avenue, Los Angeles, California 90025
Telephone: (213) 478-0711 ■ Telex: 69-1339 ■ Cable: Cinedevco

Circle 140 on Reader Service Card

PSM-8 provides switchable output impedances, coaxial or balanced output, is designed for critical production testing of channel modems, filters, 2- and 4-pole networks, or operational checks on overseas cable and the like. WANDEL & GOLTERMANN (WEST GERMANY), U.S. agent, W. & G. INSTRUMENTS, INC. 334

Audio test system measures level, frequency response, total harmonic distortion and S/N ratio on audio line. Model HS-4 includes separate generator and receiver, makes all tests in less than one minute. \$1850.00 (receiver); \$2300 (generator); \$2995 (both together). CONTROL CONCEPTS CORPORATION. 335

Distortion and noise meter has fundamental rejection tunable from 10 Hz to 30 KHz. Model F240 can also measure level from -94 dBm to +32 dBm, gain, frequency response, S/N ratio. It runs on six "C" cells. ALMALGAMATED WIRELESS (AUSTRALIA): SYSTEMS MARKETING CORP., U.S. distributor. 336

De-esser has overload/noise ratio of 100 dB, distortion below 0.1%. Dynamic Sibalance Controller has threshold control, defeat switch, 1 ms attack and 50 ms release. Unit includes three independent channels. \$395. PARASOUND, INC. 337

Automatic tape cartridge machines have non-slip stackable desk enclosures or standard rack mounts. Series will accommodate all NAB standard "A,"



"B," and "C" carts. They have air-damped solenoid operation, vernier ad-just locking head mounts, digital integrating cue detectors. \$350 to \$1375. AMPRO CORPORATION. 332

Tape recorder electronics is solid-state, designed to replace tube electronics in Ampex 300, 350/351, and 354. Model 360 electronics is plug-for-plug replacement, has regulated internal power supply, panel controls for record and playback gain, monitor and equalization switching. \$645. INOVONICS INC. 338

Urethane foam is sound transparent, can be used in speaker grilles. Filter-crest foam is available in bun, sheet and roll, and in colors. CREST-FOAM CORP. 339

Display controller provides alpha-

numeric readout from a computer data bus. R0200C Series operates with 7-bit parallel ASCII data at up to 1620 char-



acters per second, has memory for full screen, composite video output, formats up to 80 characters x 24 lines. \$790 to \$1070 (format size). ANN ARBOR TERMINALS, INC. 345

Portable dual-trace oscilloscope has de-layed sweep, 50 MHz bandwidth.

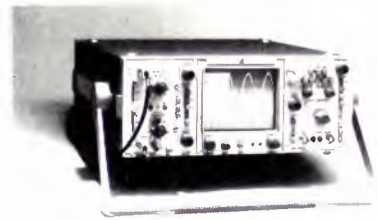

Model D75 has carrying and tilt handle, under-airplane-seat size, sensitivity to 1 mV/div (at 15 MHz bandpass). \$1375. TEKTRONIX. 346

BM/E

IBE Spotmaster

Broadcasters' Choice:



Spotmaster/Revox A77 Mark III-B

- Lifetime guarantee
- Takes 10 1/2" reels & NAB hubs
- Standard & Dolby versions
- Superb specs & performance

Spotmaster and Revox have joined forces to develop this ruggedized, rack-mounted version of the A77 stereo recorder specifically for broadcast use. Choose the standard version, or the Dolby model with its incredible 70 dB S/N ratio. All basic parts except heads, capstan and pressure roller are guaranteed for life. Your choice of 2- or 4-track stereo operation at 7-1/2 and 3-3/4 ips. Other speeds, full-track heads, accessories optional. Call or write:

BROADCAST ELECTRONICS, INC.

A Filmways Company

8810 Brookville Rd., Silver Spring, Md 20910
(301) 588-4983 • TWX 710-825-0432

Circle 141 on Reader Service Card



Send only the best.

CBS Laboratories Mark III Image Enhancer is preferred by most TV stations. Because it sharpens both vertical and horizontal detail automatically. And improves picture resolution as well as color fidelity. The Mark III, with unique "crispened-comb" filter, separates chrominance from luminance, providing sharper contrasts with more defined picture detail. Available for all monochrome and color cameras. From CBS Laboratories, of course.

CBS LABORATORIES

A Division of Columbia Broadcasting System, Inc.
227 High Ridge Road, Stamford, Connecticut 06905

Circle 142 on Reader Service Card

NEW LIT

For copies of these literature offerings, circle number for appropriate items on Reader Service Card.

"Index to Kodak Information" is a catalogue of books, pamphlets and other publications on photography, with more than 780 items. Eastman Kodak. **250**

Closed circuit television equipment is subject to 16-page catalog, including cameras, VTRs, lenses, mounts, many others. GBC CCTV Corp. **251**

Correlation and probability analyzer is fully described in eight-page brochure, with comprehensive application data. Honeywell. **252**

Cable amplifiers that transmit over video pair cable are covered in brochure on TCA units, including 5 MHz and 10 MHz versions. General Electric. **253**

Brochure on Modem test set gives full technical specifications for portable unit capable of testing and monitoring every type of data modem. Bowmar Instrument Division. **254**

Short form catalog of video instru-

ments, including sync generators, converters, bar graphs, processors, etc., is accompanied by a large maze problem for amusement of recipients. Colorado Video, Inc. **255**

Series of technical bulletins cover specifications of audio, digital and instrumentation tapes made with Thermo-465 formulation, for severe temperature conditions. Graham Magnetics. **256**

Brochure gives technical specs and applications for Model 7113 spectrum analyzer in the 0-to-1800 MHz range. Tektronix. **257**

Catalog of hobbies, scientific instruments, games, crafts lists about 4500 items. Edmond Scientific Co. **258**

Computer-compatible programmable frequency synthesizers are subject to 16-page short-form catalog, including the new 6000 series with changeable functions on plug-in cards. Adret Corporation. **259**

Four-page brochure shows 15 standard display controllers with 69 optional configurations, plus free-standing keyboards and video monitors. ANN ARBOR TERMINALS, INC. **260**

Television identification system, which takes pictures of personnel on command and "replays" them as wanted, is subject of eight-page brochure. Ampex Corporation. **261**

Rectifier bridge cross reference shows replacement capabilities of molded low-power circuit assemblies, listing over 250 devices with original and replacement part numbers. International Rectifier Corp. **262**

RF inductors, contactors, and accessories are shown in data sheets with complete specifications. Multronics, Inc. **263**

Portable instrumentation recorders are shown in new 12-page catalog, with full technical specs, design concept discussion. Gulton Industries, Inc. **264**

Catalog addition covers the most recent test and measuring instruments—RF meters, RF-DC millivoltmeters, directional power meter, frequency counters, many others. Rohde and Schwarz. **265**

Brochure covers R-40 cable trench digger, which digs to 6 feet deep, 8 inches wide, with a number of attachments for hydraulic boring, backhoe, pavement breaker, clean-up broom, and others. Ditch Witch. **266**

Chemical milling equipment is topic of four page brochure. Micro Parts, Inc. **277**

Full line of mobile and fixed duplexers can be studied with movable wheel chart, with instrument appearing in window as chart is turned and description in another window. Phelps Dodge. **278**

Listen to the Sound of Accuracy

STL test tapes are rated tops for accurate Azimuth Reference . . . the most accurate and dependable tapes you can buy.

In addition, they are available in more sizes than that offered by any other manufacturer in the world.

Produced independently to the highest standards, STL test tapes are internationally acclaimed . . . accepted as basic reference tools of unexcelled quality.

All audio widths from 150 mil. to 2-inch. Prompt delivery insures freshness.

For the distributor in your area—Call or write:

TABER Manufacturing & Engineering Company
2081 Edison Ave. • San Leandro, Ca. 94577 • (415) 635-3831
Minneapolis distributor: Sound 80, Inc.

Circle 143 on Reader Service Card



FIVE MIXER AUDIO CONTROL

B-500 series

the B-501 monaural
\$750

the B-502 stereo
\$1050

B-503 dual channel
\$950

the McM Martin

full choice line includes

the rack mount

ACCU-FIVE

mini-console, and

the eight channel

B-800 series

consoles

McMartin

McMartin Industries Inc
4500 South Seventy-sixth Street
Omaha, Nebraska 68127
(402) 331-2000 Telex 048-485

Circle 144 on Reader Service Card

NEWS

\$20,214,000 (up 25%) and earnings \$680,000 (up 146%) for year ending June 30.

Tocom, Inc.: record sales and earnings for year ended June 30, 1973 of \$2.9 million (up 67%) and \$262,000 (up 113%) . . . **CCA Electronics Corp.:** for nine months ended July 31, sales were \$4,174,572, and earnings \$154,633 . . . **Pioneer-Standard Electronics:** declared third-quarter dividend of 4 cents a share, payable November 1.

Cox Broadcasting Corp: quarterly dividend of 8- $\frac{3}{4}$ cents a share, payable October 16 . . . **International Video Corp:** record sales for year ended July 1, 1973 of \$26,969,000 (up 44%), and income of \$1,460,000 (up 80%) . . . **Harris Intertype Corp:** record sales of \$447,469,000 and net earnings of 16,363,000 for year ended June 30, 1973.

GBC Closed-Circuit TV Corp: record sales and earnings (sixth record year) for year ended May 31, 1973 of 6,588,392 and \$209,894, respectively . . . **TeleMation, Inc.:** sales 8,555,078, net income \$51,879, for six months ended June 30 . . . **Collins Radio Company:** sales \$350,000,000, up 4%, and earnings \$12.8 million, for year ended August 3, 1973.

People

Cl. Brooks Dawson is the new assistant advertising and sales promotion manager for Electro-Voice, Inc. . . . **C.L. Hendrickson** was appointed vice president, marketing, for Elpa Marketing Industries . . . **Bernadette Cash** resigned as director of community and press relations for WBBM, Chicago, to become president of LaCade Records, Inc. and is said to be first woman resident of a recording company.

J. Bryan Sullivan is president, **J.R. Eckwith** vice president, of American Ideonetics Corporation . . . **J.N. Porter** is director of marketing for CMX systems, maker of videotape editing systems . . . New director of marketing for Telemet is **Kenneth R. Schwenk**.

Advertising and sales promotion for our radio stations of McCormick Communications will be directed by **Stanley L. Schweiger** . . . **Gary H. Beeson** will be national sales manager of Avelin Electronics Division of Apolloasers, Inc.

Charles McShane left his post as director of research for Acoustic Research, Inc., where he developed some of the best known speakers in the industry, to become director of speaker research for Sherwood Electronic Laboratories . . . **Ken Schiller** joined Ana-

Alignment Problems?

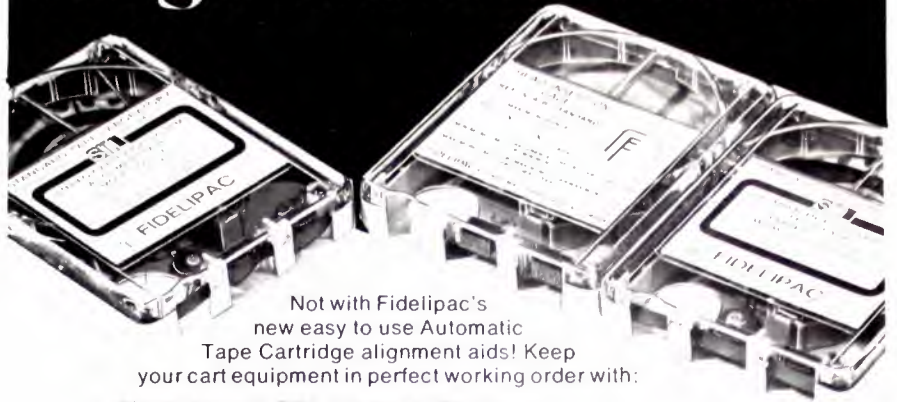

Not with Fidelipac's new easy to use Automatic Tape Cartridge alignment aids! Keep your cart equipment in perfect working order with:

- Fidelipac's 350 STA Alignment Cartridge
- Fidelipac's 350 STF Wow and Flutter Cartridge
- Fidelipac's Head Insertion Gage
- Fidelipac's Height Gage

Each one available individually or combined in a money saving kit with bonus booklet, ALIGNING YOUR CARTRIDGE SYSTEM.

Available through your Fidelipac Distributor. Order them now so you'll be broadcasting the perfect cart sound your listeners deserve.

Aligning
Your
Cartridge
System



FIDELIPAC®

3 Olney Avenue, Cherry Hill, N.J. 08034
(609) 424-1234

Fidelipac is a registered trademark of TelePro Industries Incorporated

Circle 145 on Reader Service Card

Send only the best.

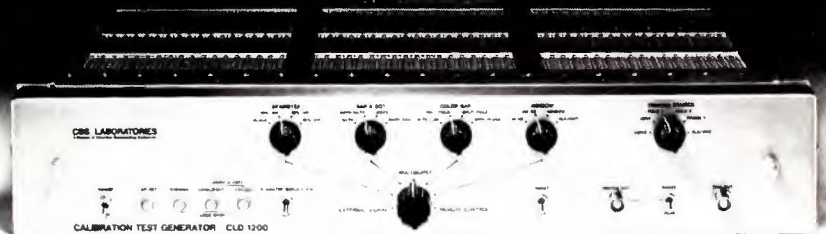

CBS Laboratories' new Calibration Test Generator puts color to the test. Providing an extremely stable signal, the CLD-1200 permits accurate testing, evaluating and calibrating of color television equipment. Digital circuitry insures precision pulse timing.

The CLD-1200's wide range of test signals far exceed industry standards. All test signals are available simultaneously!

The CLD-1200 can even be used as a standard sync generator. From CBS Laboratories, of course.

CBS LABORATORIES

A Division of Columbia Broadcasting System, Inc.
227 High Ridge Road, Stamford, Connecticut 06905

Circle 146 on Reader Service Card

What A Figure...

Marco Video Series RS Routing Switchers give you the best signal-to-noise figure for your money! 69 dB S/N assures minimal degradation of video-audio quality even when fed through the switcher many times. Add in:

- Hand-trimmed Differential Gain and Phase to meet and exceed the most stringent tolerances.
- Compact size to reduce rack space requirements.
- Configurations from 12 X 6 through 12 X 200.
- Low Price

Call DeWitt Smith today for details.



MARCO VIDEO SYSTEMS, INC.

6114 N. 20th Street, Philadelphia, Pa. 19138 • 215 VI 9-9500

Distributor and Rep inquiries invited.

Circle 147 on Reader Service Card

TAPE RACKS

90
CARTS



\$39.50

GOOD DEPENDABLE
QUALITY AT THE
RIGHT PRICE



72
CARTS

\$39.50



MICRO-TRAK

FORMERLY GRAY RESEARCH

HOLYOKE, MASSACHUSETTS 01040

Circle 148 on Reader Service Card

SAVE UP TO 50%

IN HELICAL-SCAN TAPE
AND HEADWEAR WITH
THE AUTOWINDER

Model R-1



for EIAJ 1/2"

AND REDUCE
REWIND TIME 80%

Video tapes are not lifted away from the heads during rewind. Thus, both tape & heads are unnecessarily scraped. Now you can eliminate this damage & simultaneously rewind an hour's tape in about a minute... with a smoother wind, preventing edge-damage, too. The R-1 operates unattended with automatic slowing & shutoff. Rewinds 1/4" & 1/2" audio tape, too. Maintenance free. Lasts for years.



Ultra Audio Products

BOX 921 BEVERLY HILLS, CALIF. 90213
(213) 849-1433

Request Bulletin No.

BM113

Circle 149 on Reader Service Card

conda Electronics as CATV sales representative for the Pacific northwest.

John R. Dillon will be marketing director for CATV products of Scientific-Atlanta . . . **Gerald G. Heitel** is director of sales for International Video Corporation . . . Executive secretary of the Arizona Cable Television Association is **Ivan D. Johnson**, the first full-time administrator for the association.

Milford G. Richey is vice president-engineering for American Cable Television, Inc. responsible for engineering development of new and existing cable systems . . . **Jack Sumroy** joined WSNL-TV Long Island TV station, as vice president, programming and production, after nearly two decades with NBC-TV in New York.

Anthony Gargano is manager of international marketing for Jerrold Electronics Corporation . . . **Edward J. Holton** became vice president and general sales manager of General Cable Corporation . . . **P. Kim Packard** was appointed general manager of CATV equipment and installation for GTE Sylvania, Inc.

Dr. William Rothfarb was named vice president of Network Analysis Corporation, will concentrate on CATV operations . . . **Bill Gaylord** joined Anixter-Pruzan as manager of national accounts, after 25 years with Anaconda Wire and Cable Co.

F. Dean Galey was assigned the new post of manager of product assurance for RCA Broadcast Systems, responsible for quality control from design to installation of broadcast equipment . . . **Al Bedross** joined the Coltape Division of Columbia Pictures Industries as videotape sales specialist for the New York and Philadelphia markets.

Thomas J. Cartin joined C-Cor Electronics as director of manufacturing . . . **J. Leonard Reinsch**, president of Cox Broadcasting Corp. was appointed by President Nixon to the U.S. Advisory Commission on Information; he had previously served on the Commission under Presidents Kennedy and Johnson.

David J. Chapman is marketing manager of Ampex International . . . **Theodore J. Swanson** was named director of corporate development engineering for Warner Cable Corporation . . . **Donald P. Zeifang** joined NAB as vice president, government relations.

Joe DiMaggio, the Yankee Clipper himself, became a director of Theatre-VisioN, Inc. and will concentrate on sports programming and packaging . . . **James A. Lundquist** joined Fidelipac as chief engineer, with responsibility for research and development. **BM/E**

The Versatile Varotal VRM

The VRM's ZERO MINIMUM OBJECT DISTANCE* gets you in closer than has previously been possible. In fact, you can focus right on the front glass of a VRM lens and then go out to 632mm. (24.9 inches) without refocusing. Two flip-in, split second, range extenders give you vastly more variation in close-up work than any other lens. The potential for dramatic effects with a VRM is limited only by the creative genius of your program director. Close-up dollying is controlled solely by the length of the camera itself. You can aim over the subject's shoulder and shoot gadgetry without changing focus. You can fill the screen with small objects hand-held by the subject. Close tete-a-tete between panelists, contestants and persons being interviewed can be spectacularly portrayed. The VRM is ideal for changing range without re-focusing during outside broadcasts. Unpredictable switches and turnarounds can be covered without changing focus simply by operating the easy flip-in range extenders.

*In rack focus mode

For more information about the VRM and our generous TRADE-UP policy, contact the nearest R.P.I. office.



RANK PRECISION INDUSTRIES, INC.

New York 260 N. Rt. 303 West Nyack, N. Y. 10994 (914) 358-4450
 Illinois 411 E. Jarvis Ave., Des Plaines, Ill. 60018 (312) 297-7720
 California 5437 E. Sheila St., Los Angeles, Calif. 90040 (213) 722-3221

Circle 150 on Reader Service Card



Will your next frequency counter have all these features?

Here's the first 512 MHz Frequency Counter designed specifically for communications people... Systron-Donner's Model 6252. It's the only counter offering all these features:

- Relay input protection. Indicator light and reset button.**
- Metered input. Visually indicates high/low signal strength.**
- Tone measurement. Example: measure 1020.001 Hz in 1 second.**

- Accuracy. Stabilities to 5 parts in 10⁹.**
- Built-in battery. An exclusive 6252 option. Take your counter anywhere.**
- FCC. Meets or exceeds FCC requirements.**

All of these features, plus more, for \$1,095. For immediate details, call us collect on our Quick Reaction line: (415) 682-6471. Or you may contact your Scientific Devices office or Systron-Donner at 10 Systron Drive, Concord, CA 94518.



Circle 151 on Reader Service Card

NEW! FROM LAIRD TELEMEDIA

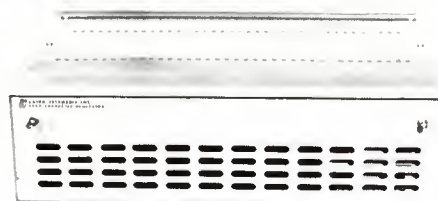

3600 VIDEO CHARACTER GENERATOR



STANDARD OPERATIONAL FEATURES OF THE 3600 INCLUDE
 • LARGE LEGIBLE FONT • 10 LINE 25 CHARACTER FORMAT • PREVIEW AND PROGRAM OUTPUTS • CRAWL AND ROLL • CHARACTER UNDERLINE AND OVERLINE • CHARACTER BOX AND FLASH • 250 CHARACTER SOLID STATE MEMORY • CLEAR LINE AND PAGE • HORIZONTAL EDGING • WINDOW FORMAT POSITIONING • SWITCHABLE VIDEO POLARITY • NON ADDITIVE MIX

PRICE INCLUDING KEYBOARD AND ALL FEATURES LISTED ABOVE \$2550

PLUS CAPABILITIES OF EXPANDABLE SOLID STATE MEMORIES UNLIMITED DATA SOURCE ACCESS MULTIPLE PROGRAM OUTPUTS

FOR MORE INFORMATION CONTACT

LAIRD TELEMEDIA INC.
 7125 SOUTH WEST TEMPLE, BOX 48, 8751
 SALT LAKE CITY, UTAH 84115

Circle 152 on Reader Service Card

about 2100 telephone calls, as they covered the debates and voting of the students who were assembled in a meeting room of the County Board Chambers.

The programs were an unqualified success for Station WKRS. Listenership is normally high, for this heavy-talk station garners over 50% of the Lake County audience, and this program added even more. A regular series of commercials went along with the programs. The station also gained strong approbation for serving the community well through the programs. Students were stimulated to start planning for next year's series, vowing to do an even more thorough and persuasive job for the "laws" they favored.

Watchers of political trends may get some interesting clues to the future, if we can use these programs as a sample of the thinking of many young people who will be voting citizens in a very few years. In general, the kids are very far from being wild-eyed radicals, but they don't, on the other hand, exhibit the big swing to stiff conservatism that some commentators have seen among young people.

If we have to characterize them at all, it might be as the "liberal-tinged center." Only one proposed bill could be called "far out" by most standards: the legalization of prostitution, which did get some negative feedback from the community. It did not survive the "Governor's" veto.

Some of the other laws they wanted, in addition to those already noted, were: a Conservation and Wildlife

Informational/Instructional Radio: New Directions

Many commercial broadcasters can truly be called "informational" radio and provide their listeners with a great deal more than news and entertainment. Special hotlines (not over-the-air) established by many stations can get quite specifically, instructional. Last spring, WMCA, New York, established a call-in number to provide metropolitan area students with help on their homework. The phones were manned by volunteer tutors. The program is not yet functioning this fall because of the problem of finding volunteers to man the phones, but the station is searching for a way to serve students.

WBCN, Boston, which has established a close rapport with college students in the area, runs a hotline which tends to be an advice-and-directory service, but engineering students have been known to call and ask for chief engineer Brian Edgerton's help in solving technical problems!

Many over-the-air call-in shows perform a service by hooking up a person-with-a-question to a person-with-the-answer. We can readily envision such a service being extended, through the use of extra phones connected to recorders to create a people's invisible university in the spirit discussed in the Wes Thomas article in this issue.

Act (okayed by the "Senate" too) which established penalties for polluters, protected wild animals and virgin land; a resolution on gun control, asking for Federal prohibition of small arms importation; state subsidized day-care centers; criminal appeals decisions within 60 days; capital punishment reinstated for certain crimes; a reorganization of the county government for higher efficiency; and protection of the confidentiality of press "sources." There were about a dozen more, equally serious. Probably the republic is going to survive! **BM/E**

Proud of your TV picture!

The new Burwen Dynamic Noise Filter gives audio to match . . .

Now you can broadcast film and video tapes with little or no distortion, full dynamic range and very low noise.

When installed in your broadcast chain, the Dynamic Noise Filter will reduce the cumulative noise from all sources preceding it 10-11 dB with no audible effect on the music or speech. This is accomplished with no less than 40 operational amplifiers and other precision components which provide 100 dB dynamic range with high accuracy, flat response over the entire range.

For complete details, call or write

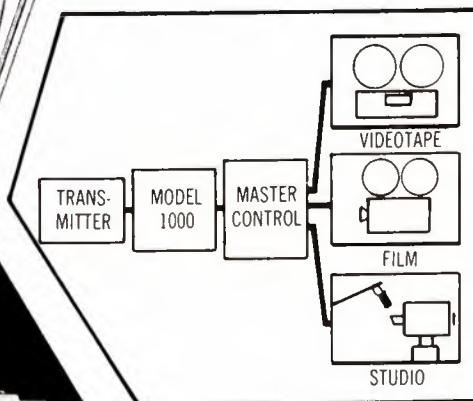
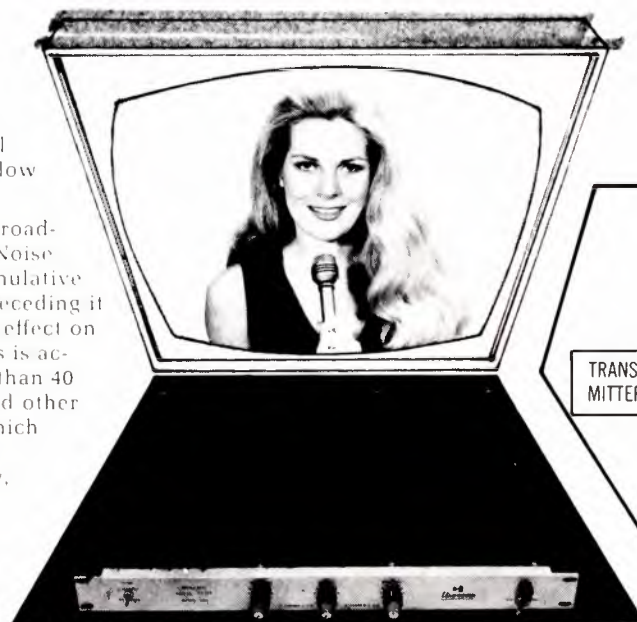

209 MIDDLESEX TURNPIKE, BURLINGTON, MA 01803 TEL (617) 273 1488

Circle 153 on Reader Service Card

VISCOUNT A GREAT WAY TO SWITCH

DELIVERY 4 TO 6 WEEKS

1050 ROUTING

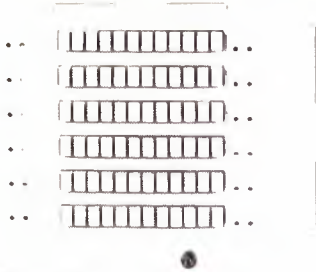

1035 ROUTING

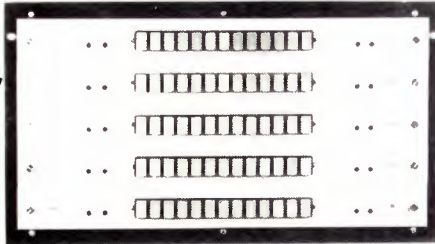

* Quasi solid state video switching. Solid state video and Audio input and output amplifiers. Output levels not affected by bus loading. The 1050 offers patch panel economy with switch convenience and performance.

PRICE EXAMPLES

INPUT	OUTPUT	VIDEO	AUDIO	AUDIO-VIDEO
12 X	3	\$ 1200	\$ 860	\$ 1490
12 X	6	1710	1370	2150
12 X	12	2920	2520	3720
12 X	18	4630	3890	5870
12 X	24	5840	5040	7440

* Fully solid state Video switching. Solid state Video and Audio input and output amplifiers. Plug in modular construction. Fully expandable in the field (input and output) by addition of plug in modules or matrices. Spare contacts for external functions remote control.

PRICE EXAMPLES

INPUT	OUTPUT	VIDEO	AUDIO-VIDEO
12 X	5	\$ 2,330	\$ 2,690
12 X	10	4,440	5,110
24 X	5	4,660	5,380
24 X	20	17,760	20,440

VISCOUNT INDUSTRIES LTD

105 EAST 69TH AVENUE, VANCOUVER, BRITISH COLUMBIA
CANADA V5X 2W9 - PHONE (604) 327-9446

Circle 154 on Reader Service Card

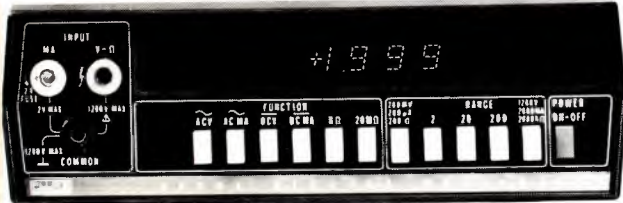

* New digital V.O.M. works well in near field environment. Only \$299.

Here's the best low cost digital voltmeter ever made for broadcast and communication use. It's got all the resistance range, voltage resolution, high ac accuracy you'll ever need plus 30 second warm-up to full accuracy. Fluke's new Model 8000A measures in 26 ranges ac/dc volts, amps and resistance from 100 μ V to 1200 V. 0.1 μ A to 2 A, and 100 milli Ω to 20 meg Ω . Basic dc accuracy, 0.1%. Full year guarantee. Option choice includes rechargeable battery pack, printer output, deluxe test leads, HV probe, RF probe, 600-amp ac current probe, carrying case, dust cover and rack mount. Unique self-zero eliminates offset uncertainty. Electronics are securely mounted in high-impact case. Service centers throughout U.S., Canada, Europe and Far East for 48-hour turnaround repair.



P. O. Box 7428,
Seattle, Washington 98133.

Get all the details from your nearest Fluke sales office. Dial toll-free 800-426-0361 for address of office nearest you.

Circle 155 on Reader Service Card

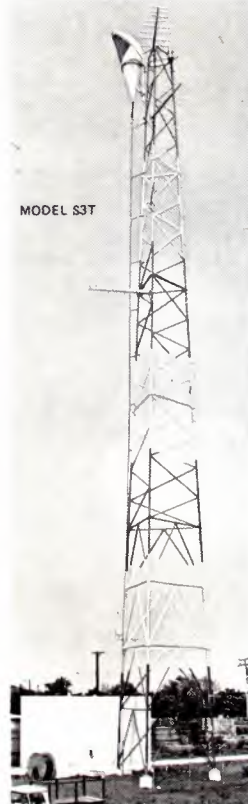

Small Tower Site? Install an S3T Self-Supporting Tower

- ▶ Basic design for a 40PSF wind-load and for support of two 10 ft. diameter high-performance antennas or two 10x15 reflectors with rigidity required for 12 GHz systems.
- ▶ Designs for heavier wind or antenna loadings available to meet your system specifications.
- ▶ Available in heights to 300 feet with construction in increments of 25 feet. Varying heights available to your specifications.
- ▶ Triangular Cross Section design — tubular construction with inside climbing ladder. All materials hot-dipped galvanized after fabrication.
- ▶ Design criteria in accordance with EIA Standard RS-222-A. All steel used in fabrication conforms to ASTM designation A-36.



Fort Worth Tower Co., Inc.

P. O. BOX 8597 / 5201 BRIDGE STREET / FORT WORTH, TEXAS 76112
FORT WORTH PH (817) JE 6-5676 • DALLAS PH (214) AN 4 2822

Circle 156 on Reader Service Card

individual human beings.

There also appears on the horizon a need for new instructional professionals in higher education. To assist professors, there will have to be a considerable number of information specialists, media technologists, and instructional technologists to create the necessary software.

From the Aspen Program on Communications and Society, from the Rand Corporation, and from Harvard University's program on informational technology, among others, numerous reports and studies are being released concerning the potential of cable television for instructional purposes. Even though this is but another delivery system, many dedicated and enthusiastic individuals tend to disregard the 20-year experience with ETV and ITV. Meetings, seminars, and conferences are being held in various parts of the United States to study the potential of cable as a delivery system for educational materials to attract new clientele, i.e., to bring the store to the consumer. There is considerable study and resource being exerted in the direction of non-traditional and innovative means of improving learning performance. In higher education there is considerable thought being given to opening up the avenue of accreditation to all who need post-secondary education. Together with the growing budgetary crunch in both public and private institutions, all hold promise for the adoption of technology for the delivery of instruction. And cable holds

forth two-way capability as well as the elimination of the scarcity factor inherent in over-the-air transmission.

One study points out that "if 20 years of largely futile experimental instructional television has shown anything, it is that such efforts stand or fall on the professional quality of the programming. Whether educators like it or not, television is firmly entrenched as an entertainment medium, and educational programming must compete in effect with all sorts of non-instructional, even mindless, fare." And this means expenditures of large sums of money. Hundreds of thousands of dollars will have to be invested in high level production of visually mediated courses. Universities are no longer dealing with captive markets. They are in a competitive situation which needs and requires serious consideration of the advantages and opportunities of the technological revolution in higher education.

While there are success stories here and there in various institutions in the United States, there are no simplistic answers available as to the precise "how" and "when" of the solutions to technology's application to education. Whether it be cable or computer, cassette or closed circuit, it will require considerably more resource to apply technology to instruction on an accelerated scale to meet the Carnegie Commission's expectations for the 1980s or the year 2000. The price of course will be high. Technological revolutions are not purchased cheaply in any field, particularly not in a field as wondrously resistant to change as higher education. While it may in fact become a fact in time, the educational technological revolution is not yet at hand. **BM/E**

PERFECT YOUR CCTV SYSTEM WITH COSMICAR[®] LENSES



TV-COSMICAR-EE 16mm F/1.6

The TV-COSMICAR-EE 16mm f/1.6 is a high-speed EE lens specially designed for 2/3" vidicon cameras. It maintains image luminance 100 lx against subject brightness between LV11.3 ~ 17 (350 ~ 18,000 cd/m²), about 1,800 ~ 96,000 lx.

The automatic electric-eye diaphragm close down completely provided that subject brightness exceeds approx. LV20 (144,000 cd/m²), 768,000 lx. In case the camera is switched off and not in operation, the automatic diaphragm closes down, completely shutting off the light for protection of the vidicon camera.

The "Change-over Switch" in front of the lens controls the operation of the diaphragm.

When the switch lever is turned on to "EE", the lens diaphragm operates as fully automatic electric-eye, and is brought on to "OPEN", the diaphragm stays fully opened condition.

Be sure to get the finest image recording results with quality Cosmicar lenses.

Also available are scores of other lenses, ranging from 8.5mm to 1,000mm telephoto, zoom and those motordriven among them, for immediate delivery, after being tailored to your specifications.



COSMICAR OPTICAL CO., LTD.

424, Higashi-Oizumi, Nerima-ku, Tokyo, Japan

Cable Address: "MOVIEKINO TOKYO"

Representative & Service Office: Asahi Optical (America) Inc. 15 East 26th Street, New York, N.Y. 10010, U.S.A.

Circle 158 on Reader Service Card

A NOISE FREE AGC AMPLIFIER WITH A DYNAMIC RANGE PRESERVER



WILKINSON ELECTRONICS GCA-1
STEREO OR MONO

- * Noise — -75db even with loss of input. Automatically "rides" gain without regard to peaks. Exclusive RMS Detector preserves dynamic range. Will not adjust gain if signal removed.
- * Distortion — 0.1% all gain settings.
- * Frequency Response — $\pm 1/4$ db 50HZ to 20KHz any gain setting.

For complete details write:

WILKINSON
ELECTRONICS, INC.

1937 MacDADE BLVD.
WOODLYN, PA. 19094

PHONE (215) 874-5236 874-5237

Circle 157 on Reader Service Card

A LIMITER WITH INSTANTANEOUS ATTACK—LESS THAN 1% DISTORTION



WILKINSON ELECTRONICS LA2-C/S
STEREO OR MONO

- * Distortion — $1/4$ % for 6db of limiting. 1% or less to 20db of limiting.
- * Attack Time — $5/4$ Radians for gain control before clipping.
- * Overlimit Attack Time — Instantaneous.
- * Compression Ratio — More than 35:1.
- * Frequency Response — + 1db 50Hz to 35KHz with full limiting.

For complete details write:

WILKINSON
ELECTRONICS, INC.

1937 MacDADE BLVD.
WOODLYN, PA. 19094

PHONE (215) 874-5236 874-5237

Circle 159 on Reader Service Card

Technical Papers Presented at the 1973 NAB ENGINEERING CONFERENCE



Now—the complete volume of Technical Papers presented at the 1973 National Association of Broadcasters Engineering Conference—available in durable, bound format, typeset in uniform style.

This complete transcript includes the technical papers presented at the Conference, plus a transcript of the FCC-Industry Panel and the panel discussion on helical scan VTRs. It is profusely illustrated, containing all the photos, slides and drawings presented with the technical talks. The presentations, all by industry experts, constitute a virtual encyclopedia on the current state of all phases of radio TV broadcast engineering.

Here is a volume that belongs on the shelf of every station library—something every broadcast engineer should read...and re-read...several times. It's a wonderful source of ideas, and provides the answers to many troublesome problems. Invaluable as an aid in helping stations make important buying and engineering decisions.

The Proceedings is 176 pages, $8\frac{1}{2} \times 11"$, and is bound in durable vinyl for convenient use. The Special Prepublication Price of \$7.95 prevails through Dec. 15, 1973; thereafter the regular list price is \$10.00. Three copies or more ordered at one time obtain a 10 percent discount.

LISTING OF CONTENTS

NAB Engineering Advisory Committee Report—Benjamin Wolfe (chairman), Post-Newsweek Stations, Washington, D.C. **Joint Committee for Intersociety Coordination Report (JCIC)**—K. Blair Benson, Society of Motion Picture and Television Engineers, Scarsdale, N.Y.

CBS Electronic News Gathering Experience—Raymond D. Schneider, CBS Television Network, New York, N.Y.

FCC/Industry Technical Panel—Moderator: James D. Parker, CBS Television Network, New York, N.Y. Panelists: Albert H. Chismark, Meredith Corp., Syracuse, N.Y.; Robert Flanders, McGraw-Hill Broadcast Division, Indianapolis, Ind.; Walter Alliss, Jr., KCRG-AM/FM/TV, Cedar Rapids, Iowa; Wallace E. Johnson, FCC Broadcast Bureau Chief; Harold L. Kassens, Assistant Chief, FCC Broadcast Bureau; Harold G. Kelley, Assistant Chief, FCC Broadcast Facilities Division.

The Broadcast Cartridge Today—James A. Lundquist, Broadcast Electronics, Silver Spring, Md.

Measuring and Adjusting the FM Stereo System—Arthur K. Peters, Consulting Engineer, Mt. Vernon, Ill.

The Evaluation and Correction of AM Transmitter Deficiencies—George C. Endres, Jr., RKO General, Inc., New York, N.Y.

Amplitude Modulation—1973—Ronald Graiff, American Broadcasting Co., New York, N.Y.

FM Translators—Robert A. Jones and Doug C. McDonell, Consulting Engineers, La Grange, Ill.

The New WGH Radio Broadcast Facilities—Joe Looper, Newport News, Va. **Active I-F Group Delay Correction of Television Transmitters**—L. J. Stanger, Gates Division, Harris-Intertype Corp., Quincy, Ill.

TV Station Weather Radar—The Technical Considerations—Walter B. Miles, Technology Service Corp., Santa Monica, Calif.

A Low-Cost TV Logging System—Robert H. Barnaby, NBC, New York, N.Y. **Helical Scan Video Recorders for Broadcast Use Panel**—Moderator: Edward H. Herlihy, Kaiser Broadcasting Corp., Boston, Mass. Panelists: Charles H. Anderson, Ampex Corp.; Keith Y. Reynolds, International Video Corp.; Stan Becker, Echo Science Corp.; C.R. Paulson, Television Microfilm Inc.

TV Automation Design Concepts—Robert J. Tarpey, Richmond Hill Laboratories, Scarborough, Ontario, Canada.

A Cartridge System for 16mm Television Film—A. E. Jackson and A. H. Lind, RCA, Camden, N.J.

Digiplex—A Digital Clue-Line Machine-Control System—Al Busch, Sarkes Tarzian, Inc. Bloomington, Ind.

minicomputers for the Control of the Broadcast Transmitter System—William J. Clark, RKO General.

A Chroma Level and Delay Corrector—D. J. Newport. **Recent Advances in the Remote Control of Television Cameras**—I. R. Young, Evershed Power-Optics, Ltd.

Modernizing Television Station Production Facilities—Rosner Lamb, Inc., New York, N.Y.

PUBLISHER'S GUARANTEE

Put the information in this book to work for you for 10 days. If it doesn't prove to be worth several times its cost, return it and we'll cancel invoice.

NO-RISK COUPON—MAIL TODAY!

TAB Books, Blue Ridge Summit, Pa. 17214
Please send me _____ copies of "Technical Papers Presented at the 1973 NAB Engineering Conference" at the special prepublication price of only \$7.95. (10% discount on 3 copies or more.)
I enclose \$ _____
 Please invoice on 10 day FREE trial
Name _____ Phone _____
Company _____
Address _____
City _____ State _____ Zip _____
SAVE POSTAGE by paying with order.
Foreign add 10%. Pa. add 6% tax. B-113

Circle 160 on Reader Service Card

BM/E CLASSIFIED MARKETPLACE

CLASSIFIED ADVERTISING RATES (Effective January 1, 1974)

DISPLAY CLASSIFIED ADVERTISING: \$32.50 per inch 1x; \$30.00 per inch 6x; \$27.50 per inch 12x. ALL OTHER CLASSIFIED ADVERTISING 35¢ per word; minimum \$3.50. BLIND BOX NUMBER: \$1.00 extra charge. Replies sent to address below will be forwarded to you. PAYABLE IN ADVANCE; send check with order. CLOSING DATE: 5th of 2nd month preceding issue date.

BM/E, Monterey and Pinola Avenues, Blue Ridge Summit, Pa. 17214 Phone 717/794/2191

HELP WANTED

PROFESSIONAL AUDIO ENGINEERING MANAGER

Ampex, located on the San Francisco peninsula, is expanding its product design and development programs in professional audio products and systems.

Due to this expansion, we have an immediate opportunity for an Engineering Manager to direct the design efforts for professional audio recorders and related products for our Audio-Video Systems Division.

To qualify for this position, you must possess strong technical and management experience. You will be responsible for the technical direction of several design teams and these responsibilities will include supervision of control budgets, cost analyses and schedules.

For immediate consideration for this opportunity to join the World Leader in Professional Audio-Video Product Design and Marketing, please send your resume confidentially to: R. Denison Ampex Corporation, 401 Broadway, Redwood City, CA. 94063. An Equal Opportunity Employer M/F

AMPEX

TV TECHNICIAN/ENGINEER

Opening at the State University College at Oneonta for someone with Associate degree or equivalent to work in the Educational Communications Department. Experience in the maintenance of television equipment and rear screen television systems preferred. Duties include maintenance of Studio TV cameras, Field TV equipment, Rear screen television systems, Classroom TV receivers and Associated Transmission System. Assist in MCR operations, TV Studio and Field Operations. Assist in maintenance of Audio Record Playback Facilities.

Many benefits include: Health insurance, Dental insurance, Disability insurance, Vacation, Sick Leave, Holidays. Pleasant college town in scenic part of state with excellent hunting, fishing, camping and other recreational facilities. Write: Director of Educational Communications, State University College at Oneonta, Oneonta, N.Y. 13820

AN EQUAL OPPORTUNITY AFFIRMATIVE ACTION EMPLOYER

SITUATIONS WANTED

Technician with good background in TV transmitters and studios seeks responsible position in Mid Atlantic Area. Particulars available: Box 1073-L, c/o BME, Blue Ridge Summit, PA 17214

EQUIPMENT FOR SALE

QUALITY AUDIO CONSOLES are our specialty. Modern styling with slide faders. We manufacture eight standard consoles at very competitive prices. However, if you prefer, we'll manufacture a custom system to your specifications. Also, plug-in audio modules including distribution amplifiers, pre-amplifiers, monitor amplifiers, etc. Write or phone for prices and specifications. SYSTEMS ENGINEERING COMPANY P.O. Box 89224 Atlanta, GA 30329 (404) 482-2116

EQUIPMENT FOR SALE (Cont'd)

Ready for Video—Painlessly?

We are offering, at a fraction of the original cost, a complete mobile, monochrome studio facility. Included: 2-RCA PK-330 live cameras, RCA 8-input video switcher with Ball Bros. special effects, 2-Ampex 660B VTRs with edicon and full audio mixing facilities, complete pix and waveform monitoring. Everything in working order, housed in 3 integrated 19" consoles with full-length "producer's desk." All you need do is supply A.C.

Detailed list and/or visual inspection upon request. Original cost: approx. \$65,000. Make us your best bid.

Norm Friedman
Visual Information Systems
15 Columbus Circle
New York, N.Y. 10023
(212) 541-8080.

BROADCAST AND RECORDING EQUIPMENT—Saul K. VEE International, Microtech, Langwin, Electro-dyne, Q.R.K., Micro Trak, MRL, Nortronic, McMartin, F.R.E.I., E.V., A.K.G., Stevenson, Gately, D.B.V., Advant, Altec, Fairchild, Audio Designs, 3M, Magnicon, Telex, Incomex, Nagra, Uher, Tape-A-Thon, Package Deals, Installations, Service, Request Flyer: Wengand Audio, Middleburg, PA 17842 (717) 837-1444

CARTRIDGE TAPE EQUIPMENT—Rebuilt. New paint, heads, flywheel, pressure roller, belts etc. Spotlessly clean and thoroughly tested. 90-day money back guarantee, 90-day warranty. Also contact us for possible discounts on new equipment and accessories.

AUTODYNE, Box 1001,
Rockville, Maryland 20850
(301) 762-7626

MOTORS FOR SPOTMASTERS

NEW Paper-bysteresis synchronous motor HSZ 20.50.4.170H as used in series 100 and 500 machines. Price \$29.00 each (paid while they last). 90-day warranty. Terms: check with order only, no CODs. Not recommended for Tape-caster series 100 or 500.

TAPE-ASHER ICM, INC., Box 602
Rockville, Maryland 20851

Solid-state audio modules console kits, power amplifier kits, power supplies, Octal plug-ins, mic, eq, line, disc, tape play, tape record, amplifiers, Audio & tape bias oscillators. Over 50 audio products. Send for free catalog and applications. Opamp Labs, Inc., 172 So. Alta Vista Blvd., Los Angeles, Calif. 90036 (213) 934-3566

Need 3-340-ft guyed towers, ground wire, mesh, strap, etc. What do you have, how much, when, and where?

Box 4371
Englewood, CA 90309

We are building an entire AM station from scratch. We need studio equipment. What do you have, how much, when, and where?

Box 4371
Englewood, CA 90309

PARTS—for SPOTMASTER cartridge units. IN STOCK. Immediate delivery, new and used equipment, too! LOW PRICES. COMMUNICATION MEDIA, Box 54, Allentown, PA 18105 (215) 437-0607 or 437-9447

Surplus Audio Patch Panels All Standard Configurations. Gulf Telephone & Electronics, Inc. 6245 Beverly Hill, Houston, Texas 77027

RCA RT-7 cart playback and record units, used but in good working condition. Call area code (503) 269-9776 or 269-9744

EQUIPMENT FOR SALE (Cont'd)

AMPEX VIDEO RECORDER Model VTR 7000. Factory rebuilt. 10 hours use. \$750. Radio-TV Reports, 1723 W. Howard, Evanston, Ill. 60202.

Color Time Base Correctors. Model 4102 for Broadcasting IVC 900 and 960 Series, VTRs. Excellent condition. 2 units recently factory updated. Call (904) 354-2806.

PROFESSIONAL RECORDING AND TEST EQUIPMENT for recording studios and broadcasters—Altec, Ampex, 3M, GR, HP, Tektronix—new and used. Free equipment list or drop in. Chas. E. Washburn Co., 6114-M Santa Monica Blvd., Hollywood, CA. 90038

AMERICA'S LARGEST STOCK AND CONSIGNMENT LISTING of new and used broadcast and recording equipment. We trade-sell and buy. THE MAZE CORPORATION, P.O. Box 6636, Birmingham, Ala. 35210.

FIELD STRENGTH METER. 540 KHz to 5MHz. Ten microvolts to 10 volts per meter. New solid state design, long battery life. Stable accurate calibration. Free literature. Solar Electronics, 901 No. Highland Ave., Hollywood, Cal. 90038.

The complete and reliable source for new and used broadcast equipment. Request our free listings. Broadcast Equipment and Supply Co., Box 3141, Bristol, Tennessee 37620.

MICA AND VACUUM transmitting capacitors. Large stock; immediate delivery. Price lists on request. SURCOM ASSOCIATES, 1147 Venice Blvd., Los Angeles, Cal. 90015 (213) 382-6985.

4—650 ft. towers \$6500.00 each. Many more. Ground wire 85c per xx. lb. Bill Angle, Box 55, Greenville, N.C. 27834. Tel. 919-752-3040.

One stop for all your professional audio requirements. Bottom line oriented. F.T.C. Brewer, Box 8057, Pensacola, Fla. 32505.

WE BUY TUBES, TRANSISTORS & CAPACITORS. Send your lists of sale items. Specialty Supply Ltd., P.O. Box 22391, Denver, Colo. 80222.

CAPSTAN IDLERS for AMPEX 300, 350, 440. Series, self aligning with replaceable ball bearings, \$22.50 net. VIF INTERNATIONAL, Box 1555, Mtn. View, Ca. 94040.

EQUIPMENT WANTED

ATTENTION RADIO STATIONS

Central American Organization wants used and in good condition, several Marti transmitters, models M-30 BT/TPS and Marti receiver MR-30, both to the frequency of 150-170 MHz. Also 5 kilowatt AM transmitters. Age is not important, as long as the equipment is working, dependable and in good condition.

Please send all correspondence by airmail to: Organizacion Ali u's, 7a. Avenue #4-00 Zona 1, Chiquimula, Guatemala, C.A.

INSTRUCTIONS

FCC FIRST CLASS RADIOTELEPHONE LICENSE IN SIX WEEKS. Classes in Dallas, Atlanta, Denver, Ft. Worth, Hartford, Houston, Memphis, Nashville, New Orleans, Oklahoma City, and San Antonio. For information contact Elkins Institute, 2727 Inwood Rd., Dallas, Tex. 75235 214/357-4001.

ATTENTION VETERANS! First class license in five weeks with complete theory and R.C.A. equipped laboratory training. Approved for veterans Tuition \$333.00. Housing cost \$16.00 per week. American Institute of Radio, 2622 Old Lebanon Road, Nashville, Tenn. 37214. 615-889-0469.

First phone through tape recorded lessons at home plus one week personal instruction in Washington, D.C., Atlanta, Boston, Detroit, New Orleans, Minneapolis, Seattle, Denver, Portland, Los Angeles. Proven results. Our 17th year teaching FCC license courses. Bob Johnson Broadcast License Training, 1060D Duncan, Manhattan Beach, Calif. 90266. 213-379-4461.

PROGRAM SERVICES

"Free" Catalog . . . Everything for the deejay! Comedy, books, airchecks, wild tracks, old radio shows, and more! Write: Command, Box 26348-A, San Francisco 94126.

PROGRAM SERVICES (Cont'd)

EXTRA VOICES FOR YOUR STATION

Copy, production, voice service for automation. Three Announcers. SUPER LOW PRICES.

Greg Sureck
Box 338
Madisonville, KY. 42431

TAPES FOR AUTOMATION



THE CnB STUDIOS
Specializing in Custom Services
3415 BERESFORD AVENUE
BELMONT, CALIFORNIA 94002
415 / 592-6149

Deejays! 11,000 classified gag lines. \$10.00 Unconditionally guaranteed. Comedy catalog free. Edmund Orrin, Box 679-M, Mariposa, Cal. 95338

PROFESSIONAL CARDS

COHEN & DIPPELL
CONSULTING ENGINEERS
Formerly GEO. C. DAVIS
527 Munsey Bldg.
(202) 783-0111
Washington, D. C. 20004
Member AFCCCE

JANSKY & BAILEY
TeleCommunications Consulting
Department
CATV & CCTV
Phone 703/354-3400-ext. 722 or 2400
Shirley Hiway at Edsall Road
Alexandria, Virginia 22314
Atlantic Research Corporation

CHU ASSOCIATES, INC.
Telecommunications Division
AM—FM—TV—CATV
Applications—Facilities Planning
Field Surveys and Proofs
Appraisals
800 Fester St., El Cajon, Ca. 92020
(714) 442-9459
TWX 910 331 1178

VIR JAMES
CONSULTING RADIO ENGINEERS
Applications and Field Engineering
Computerized Frequency Surveys
345 Colorado Blvd.—80206
(303) 333-5562
DENVER, COLORADO
Member AFCCCE

BROADCAST STUDIO DESIGN

Control Systems, Facilities Planning,
Plant Layout & Manufacturing

DYMA ENGINEERING, INC.
Route 1, Box 51, Taos, New Mexico 87571
Phone: 505/758-2686

RALPH E. EVANS ASSOCIATES

Consulting Radio Engineers
AM - FM - TV - CATV - ITFS
3500 North Sherman Blvd.

MILWAUKEE, WISCONSIN 53216
Phone: 414-442-4210

McCLANATHAN & ASSOCIATES

Consulting Engineers

APPLICATIONS & FIELD ENGINEERING
TURNKEY INSTALLATIONS—RADIO & TV
Domestic and Foreign
P. O. Box 750
PORTLAND, OREGON 97207
Phone: 503/246-8080

BE Spotmaster

Compressor-Limiter Amplifier



(The Great Leveler)

\$465!

You can stop riding gain now, even when a shouter and whisperer are on the same talk show. The Model CLA 20/40 Compressor-Limiter Amplifier does it automatically . . . instantaneously . . . for both AM and FM. Switchable controls permit symmetrical (FM) or asymmetrical (AM) peak limiting; pre-emphasized or flat response; compress limit, compress only, or compress limit off. Automatic gain control range is 40 dB dynamic, and the compression ratio is better than 10:1. All solid state, plug-in modular construction assures trouble-free reliability. Write for details.

BROADCAST ELECTRONICS, INC.

A Filmways Company

8810 Brookville Rd., Silver Spring, Md. 20910
(301) 588-4983 • TWX 710-825-0432

Circle 161 on Reader Service Card

USE BM/E's CLASSIFIED MARKETPLACE TO REACH OVER 28,000 BROADCASTERS!

To find a job or fill one, to sell a product or service . . . send your ad (along with a check) to:

BM/E
Classified Advertising Dept.
Blue Ridge Summit, Pa. 17214
717-794-2191

SALES OFFICES

Broadband Information Services, Inc.
274 Madison Avenue
New York, New York 10016.

EASTERN STATES
274 Madison Avenue
New York, New York 10016
212-685-5320
Charles C. Horner

MIDWESTERN STATES
New York Office

WESTERN STATES
1111 Hearst Building
San Francisco, California 94130
415-362-8547
William J. Healey

16400 Ventura Blvd.
Encino, California 91316
213-981-4721
Art Mandell

JAPAN

Nippon Keisoku Inc.
P.O. Box 410
Central Tokyo, Japan
Tokyo (03) 667-7681
Yoshi Yamamoto

new 75Ω video delay for 19" racks

- * ±0.1 dB ripple up to 5.5 MHz
- * up to 2 μs (1,300 ft coax) in one unit
- * 'Base' delay to order plus 165 ns infinitely adjustable
- * Built-in equalizers

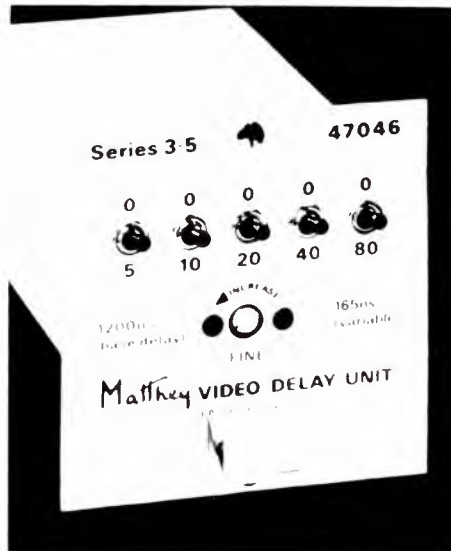

Data from



Television Equipment Associates

Box 1391 • BAYVILLE, N. Y. 11709
516 • 628-8068

BILL PEGLER

Circle 162 on Reader Service Card

RAPID-Q™ 3000

CARTRIDGE TAPE EQUIPMENT

- RAPID-Q Adjustable Delayed Automatic Fast Forward Standard
- Modular Independent Units Single, Dual, or Triple Cases
- Rack or Desk Top Mount
- Superior Performance
- RECORD ■ PLAY ■ MONO ■ STEREO MODULAR UNITS



RAPID-Q

1216 KIFER ROAD SUNNYVALE, CALIF. 94086
(408) 736-8737

Circle 163 on Reader Service Card



PASSING THE BUCK?

Don't. Production profits are up to you.
GRANDSON is on the way with help.



auditronics, inc.
P.O. Box 12637 • Memphis, Tennessee 38112

Circle 164 on Reader Service Card

AKAI America Ltd.	Cover 2
American Home Assurance Co.	33
American Telephone & Telegraph Co.	31
Amperex Electronic Corp.	CM/E-7
Amplex Corp.	28, 29
Auditronics, Inc.	84
Belar Electronics Laboratory Inc.	20
Bell & Howell, Audio Visual Products Div.	65
Bosch Corp., Robert, Fernseh Div.	66, 67
Broadcast Electronics Inc.	12, 73, 83
Burwen Laboratories Inc.	78
CBS Laboratories, A Division of Columbia Broadcasting System Inc.	73, 75
Canon Inc.	30
Cinema Products Corp.	11, 72
Cosmicar Optical Co., Ltd.	80
Datavision Inc.	16
Delta-Benco-Cascade Ltd.	CM/E-13
Ditch Witch	CM/E-25
Dynair Electronics	3
Dynasciences Corp.	17
EMT/Gotham Audio Corp.	26
Electrohome Ltd.	CM/E-26
Electronic Industrial Engineering	CM/E-21
Fidelipac	75
Fluke	79
Fort Worth Tower Co., Inc.	79
Frost & Sullivan, Inc.	CM/E-30
GTE Sylvania	58, 59
Gates Division, Harris	19
General Cable Corp.	CM/E-22, 23
Gotham Audio Corp.	26
Grass Valley Group, Inc., The	5
Heller-Oak Finance Corp.	CM/E-17
Hitachi Shibaden Corp. of America	Cover 3
International Tapetronics Corp.	25
JVC Industries Inc.	CM/E-5
LPB Inc.	71
Laird Telemedia Inc.	77
McCurdy Radio Industries Inc.	23
McMartin Industries Inc.	74
Magnavox, Video Systems Div.	CM/E-8, 9
Marco Video Systems Inc.	76
Micro-Trak Corp.	76
Myers-Oak	CM/E-32
Oak Industries Inc., CATV Div.	CM/E-29
Pacific Recorders and Engineering Corp.	71
Panasonic Video Systems	38, 39
Potomac Instruments Inc.	18
Prodelin Inc.	8
Quick-Set	CM/E-30
RCA Broadcast Systems	14, 15
RCA Electro Optics	45
Rank Precision Industries Inc.	77
Rapid Q	84
Richmond Hill Laboratories Inc.	24
SOS Video Equipment	CM/E-27
Scientific-Atlanta	CM/E-27
Scott-Buttner Coastcom	70
Scully/Metrotech Divisions of Dictaphone	60
Shure Brothers Inc.	21
Skirpan Lighting Control Corp.	32
Sony Corp. of America	CM/E-2, 3
Stanton Magnetics Inc.	70
Systems Wire & Cable Co., Inc.	CM/E-31
Syston-Donner	77
TAB Books	81
Taber Manufacturing & Engineering Co.	74
Tape-Athon Corp.	CM/E-28
Tascam Corp.	46
Tektronix Inc.	9
Telemet	68
Television Equipment Associates Inc.	84
Television Microtime Inc.	13
Time & Frequency Technology Inc.	10
Treise Engineering Inc.	CM/E-24
Ultra Audio Products	76
Universal Media Corp.	Cover 4
Videomax Corp.	7
Viscount Industries Ltd.	79
Wilkinson Electronics Corp.	81
World Cable	CM/E-15

the end.



1/2" color cartridge video recorder (SV-530) and 15" color monitor (CM-520).

Reel-to-reel video recorders were the beginning.

We feel our new 1/2" color cartridge video recorder is the end.

The 1/2" EIAJ format offers you 1/2 hour of superior record and playback. And it's only one-fourth the size of a cassette.

The SV-530 lets you use existing 1/2" EIAJ color or black and white tapes without loss of resolution. No need to dupe or dub.

Pop-in a cartridge. Then, instant-response, solenoid-activated keyboard controls let you move to any function — Play, Record, Fast Forward, Rewind or Positive Stop. The tape rewinds, and the cartridge ejects . . . automatically.

The superbly crafted SV-530 has a decorator wood case and weighs only 46 lbs. A true portable. And it's compatible with all EIAJ type-1 VTRs.

Compare performance and cost of the SV-530 with any other make or format. We think you'll agree from the beginning that ours is the end. From Hitachi-Shibaden . . . "The Image Makers".



HITACHI SHIBADEN
Corporation of America

Exec. Off: 58-25 Brooklyn-Queens Exp'y,
Woodside, N.Y. 11377 Phone 212-898-1261
Offices in Chicago, Los Angeles, Dallas, Toronto

Circle 165 on Reader Service Card

Meet the new family.



UNIMEDIA SMT-17 \$1070



UNIMEDIA SMT-15 (\$945) with ST-100 TUNER \$495



UNIMEDIA SMT-12 \$870



UNIMEDIA SMT-III \$825 to \$1695

Studio quality color monitors

Not just one model, but a whole family of rackmounted studio quality color monitors in four different sizes and seven different models.

Unimedia's SMT Series of Trinitron[®] color monitors are specifically engineered for quality broadcast, closed-circuit, cable and teleproduction applications.

All SMT Series color monitors rackmount in standard 19-inch equipment racks and the handy 9-inch model comes in a portable case as well.

SMT Series color monitors are just some of Unimedia's imaginative ideas, systems and products for the world of audiovisual communications. ©TM Sony Corporation

UNIVERSAL MEDIA CORPORATION 2301 INDUSTRIAL PARKWAY WEST HAYWARD CA 94545 (415) 782 2600

unimedia
unimedia
unimedia
unimedia

Circle 166 on Reader Service Card